

---

INDEX

I. Application.....	3
II. Preparation.....	4
2. Connectors and wiring.....	4
2.1 RS-232C Remote control.....	4
2.2 LAN control.....	4
III. Communication specification.....	5
3. Communication Parameter.....	5
3.1 RS-232C Remote control.....	5
3.2 LAN control.....	5
3.3 Communication timing.....	5
4. Communication Format.....	6
4.1 Header block format (fixed length).....	7
4.2 Message block format.....	9
4.3 Check code.....	11
4.4 Delimiter.....	12
5. Message type.....	13
5.1 Get current Parameter from a monitor.....	13
5.2 "Get parameter" reply.....	14
5.3 Set parameter.....	16
5.4 "Set parameter" reply.....	17
5.5 Commands.....	18
5.5.2 Get Timing Report and Timing reply.....	18
5.5.3 NULL Message.....	19
IV. Control Commands.....	20
6. Typical procedure example.....	20
6.1. How to change the "Backlight" setting.....	20
6.2. Operation Code (OP code) Table.....	23
7. Power control procedure.....	26
7.1 Power status read.....	26
7.2 Power control.....	28
10. Get Timing Report.....	30
10.1 Get Timing Report and Timing reply.....	30
11. Serial No. & Model Name Read.....	32

11.1 Serial No. Read .....	32
11.2 Model Name Read .....	34
12. Firmware Version .....	36
12.1 Firmware Version Read.....	36
13. LAN MAC Address .....	38
13.1 LAN MAC Address Read.....	38
14. Direct TV Channel Read & Write .....	40
14.1 Direct TV Channel Read & Reply.....	40
14.2 Direct TV Channel Write & Reply .....	41
15. Input Name .....	42
15.1 Input Name Read.....	42
15.2 Input Name Write .....	44
15.3 Input Name Reset.....	46

## I. Application

This document defines the communications method for control of the NEC LCD monitor, Exx7 series when using an external controller.

## II. Preparation

### 2. Connectors and wiring

#### 2.1 RS-232C Remote control

Connector: 9-pin D-Sub

Cable: Cross (reversed) cable or null modem cable

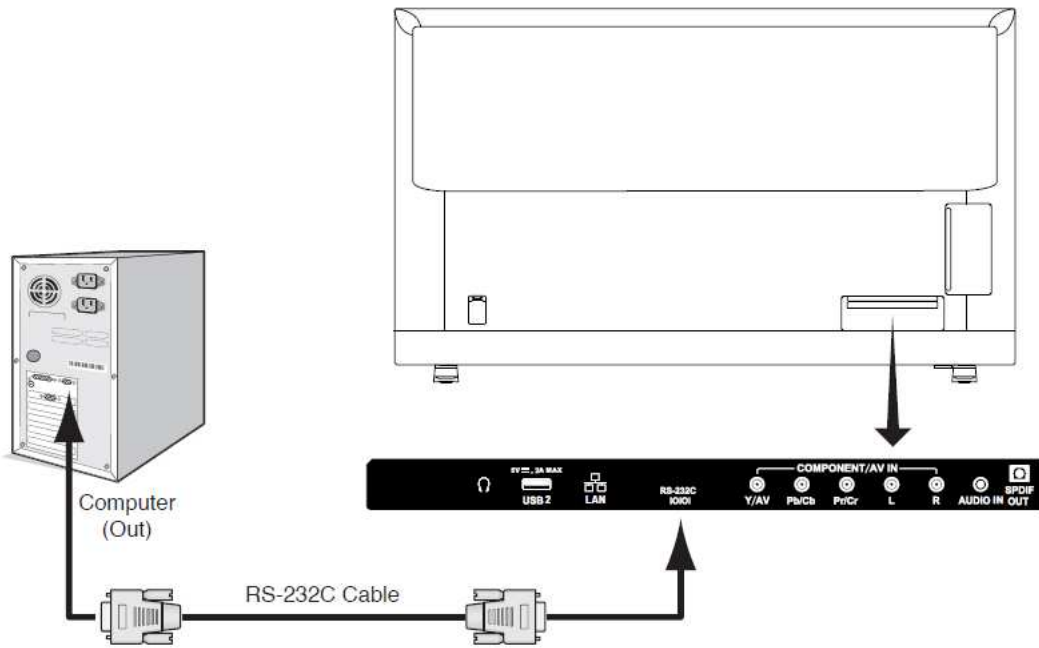

(Please refer "Controlling the LCD TV via RS-232C Remote control" on User's manual.)

#### 2.2 LAN control

Connector: RJ-45 10/100 BASE-T

Cable: Category 5 or higher LAN cable

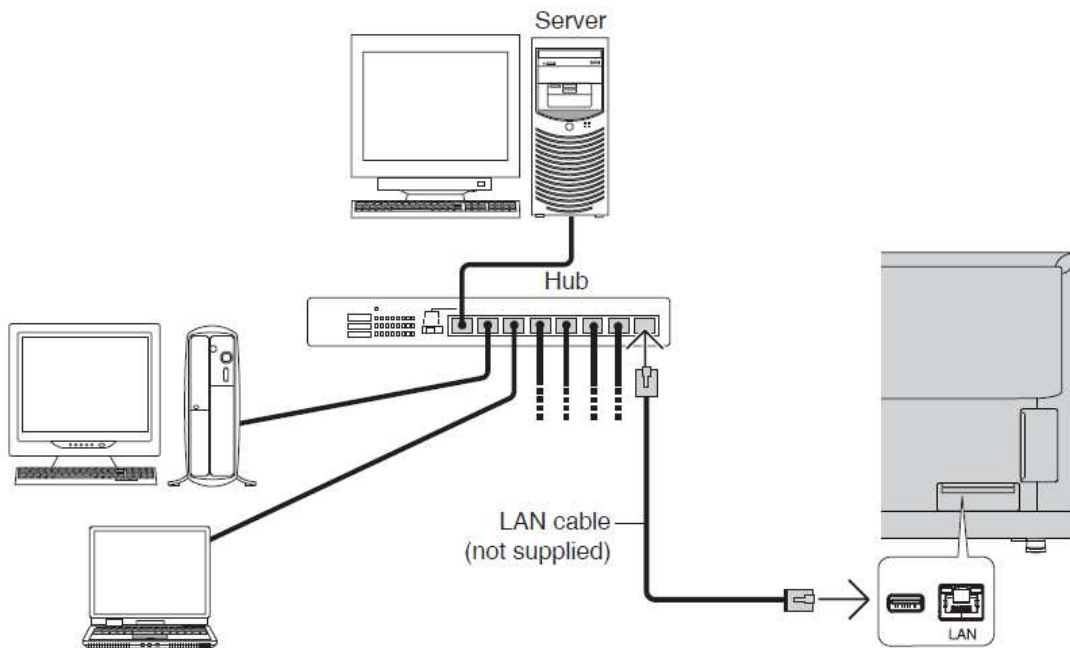

(Please refer "Controlling the LCD TV via LAN control" on User's manual.)

### III. Communication specification

#### 3. Communication Parameter

##### 3.1 RS-232C Remote control

(1) Communication system	Asynchronous
(2) Interface	RS-232C
(3) Baud rate	9600bps
(4) Data length	8bits
(5) Parity	None
(6) Stop bit	1 bit
(7) Communication code	ASCII

##### 3.2 LAN control

(1) Communication system	TCP/IP (Internet protocol suite)
(2) Interface	Ethernet (CSMA/CD)
(3) Communication layer	Transport layer (TCP) * Using the payload of TCP segment.
(4) IP address	(Default) Automatic setup * If you need to change, Please refer "Network settings" on User's manual.
(5) Port No.	7142 (Fixed)

(Note)

The monitor will disconnect the connection if no packet data is received for 15 minutes. And the controller (PC) has to re-connect to control the monitor again, after 15 minutes or more.

##### 3.3 Communication timing

The controller should wait for a reply packet before the next command is sent.

(Note)

When the following commands are sent, a controller should wait for specified period after receiving the reply command before sending the next command.

- Power On, Power Off: 15 seconds
- Input, Factory Reset: 10 seconds

## 4. Communication Format

Header	Message	Check Code	Delimiter
--------	---------	------------	-----------

The command packet consists of four parts, Header, Message, Check code and Delimiter.  
 Note: Don't add extra data (Example: padding data) after Delimiter.

Recommended sequence of a typical procedure to control a monitor is as follows,  
 [A controller and a monitor, two-way communication composition figure]

- For the general command (see the part "6.3. Operation Code (OP code) Table")

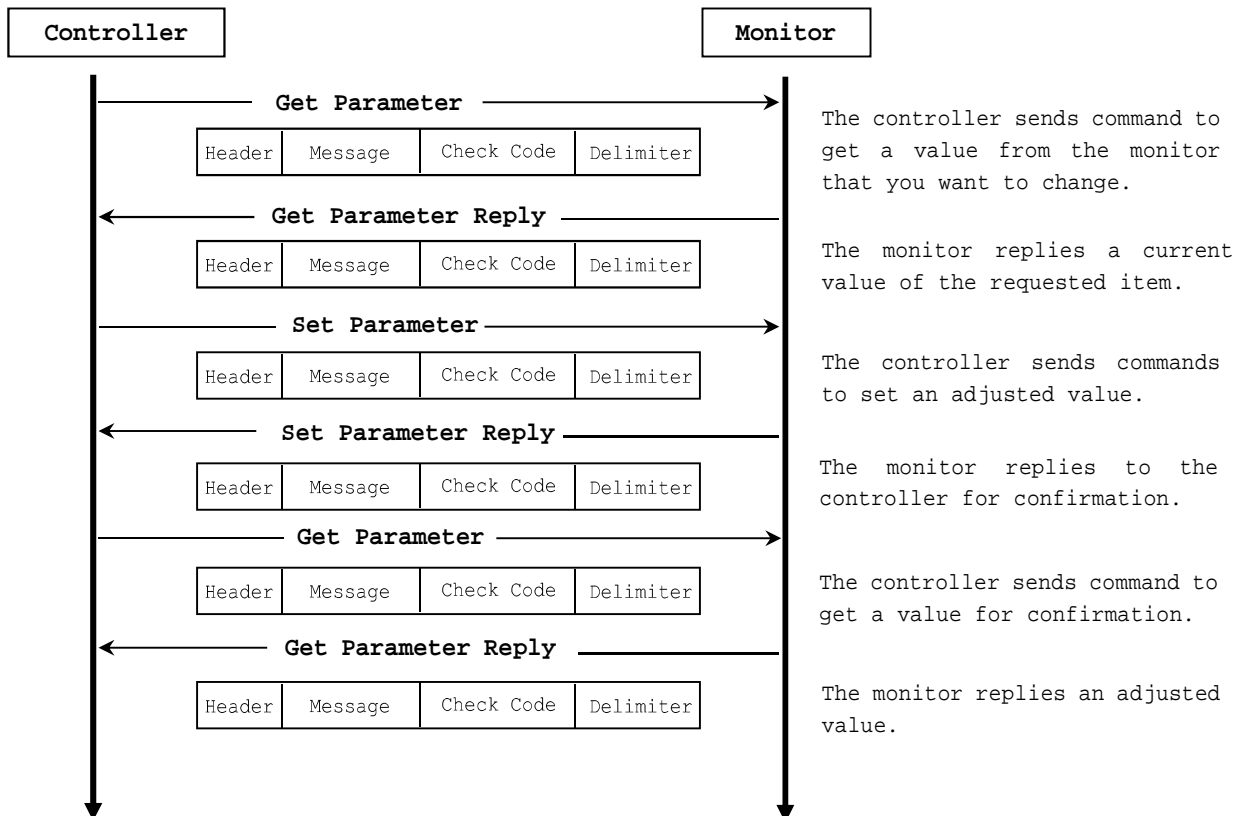

- For the special command (see the part 7 to 24. and 5.5.2)

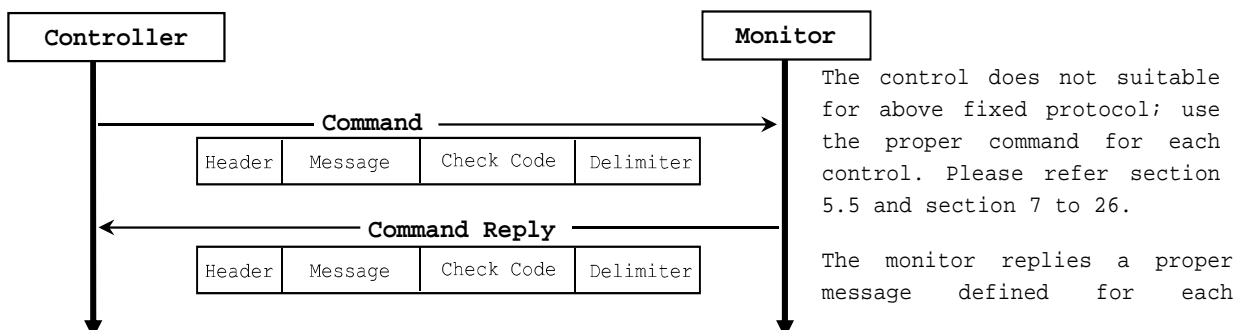

#### 4.1 Header block format (fixed length)

Header	Message	Check code	Delimiter
--------	---------	------------	-----------

SOH	Reserved '0'	Destination	Source	Message Type	Message Length
1 <sup>st</sup>	2 <sup>nd</sup>	3 <sup>rd</sup>	4 <sup>th</sup>	5 <sup>th</sup>	6 <sup>th</sup> - 7 <sup>th</sup>

1<sup>st</sup>byte) SOH: Start of Header

ASCII SOH (01h)

2<sup>nd</sup>byte) Reserved: Reserved for future extensions.

On this monitor, it must be ASCII '0'(30h).

3<sup>rd</sup>byte) Destination: Destination equipment ID. (Receiver)

Specify a commands receiver's address.

The controller sets the "MONITOR ID" of the monitor controlled in here.

On the reply, the monitor sets '0' (30h), always.

"MONITOR ID" to "Destination Address" conversion table is as follows,

Monitor ID	Destination Address	Monitor ID	Destination Address	Monitor ID	Destination Address	Monitor ID	Destination Address
1	41h('A')	26	5Ah('Z')	51	73h	76	8Ch
2	42h('B')	27	5Bh	52	74h	77	8Dh
3	43h('C')	28	5Ch	53	75h	78	8Eh
4	44h('D')	29	5Dh	54	76h	79	8Fh
5	45h('E')	30	5Eh	55	77h	80	90h
6	46h('F')	31	5Fh	56	78h	81	91h
7	47h('G')	32	60h	57	79h	82	92h
8	48h('H')	33	61h	58	7Ah	83	93h
9	49h('I')	34	62h	59	7Bh	84	94h
10	4Ah('J')	35	63h	60	7Ch	85	95h
11	4Bh('K')	36	64h	61	7Dh	86	96h
12	4Ch('L')	37	65h	62	7Eh	87	97h
13	4Dh('M')	38	66h	63	7Fh	88	98h
14	4Eh('N')	39	67h	64	80h	89	99h
15	4Fh('O')	40	68h	65	81h	90	9Ah
16	50h('P')	41	69h	66	82h	91	9Bh
17	51h('Q')	42	6Ah	67	83h	92	9Ch
18	52h('R')	43	6Bh	68	84h	93	9Dh
19	53h('S')	44	6Ch	69	85h	94	9Eh
20	54h('T')	45	6Dh	70	86h	95	9Fh
21	55h('U')	46	6Eh	71	87h	96	A0h
22	56h('V')	47	6Fh	72	88h	97	A1h
23	57h('W')	48	70h	73	89h	98	A2h
24	58h('X')	49	71h	74	8Ah	99	A3h
25	59h('Y')	50	72h	75	8Bh	100	A4h
ALL	2Ah('*')						

Ex.) If you want to control a monitor that has the "ID No." as '1', specify a destination address 'A'(41h). If you want to control all of the monitors which are connected by a daisy chain, specify a destination address '\*'(2Ah).

4<sup>th</sup>byte) Source: Source equipment ID. (Sender)

Specify a sender address.

The controller must be '0' (30h).

On the reply, the monitor sets the own MONITOR ID in here.

5<sup>th</sup>byte) Message Type: (Case sensitive.)

Refer to section 4.2 "Message block format" for more details.

ASCII 'A' (41h): Command.

ASCII 'B' (42h): Command reply.

ASCII 'C' (43h): Get current parameter from a monitor.

ASCII 'D' (44h): "Get parameter" reply.

ASCII 'E' (45h): Set parameter.

ASCII 'F' (46h): "Set parameter" reply.

6<sup>th</sup> -7<sup>th</sup> bytes) Message Length:

Specify the length of the message (that follows the header) from STX to ETX.

This length includes STX and ETX.

The byte data must be encoded to ASCII characters.

Ex.) The byte data 3Ah must be encoded to ASCII characters '3' and 'A' (33h and 41h).

The byte data 0Bh must be encoded to ASCII characters '0' and 'B' (30h and 42h).



## 4.2 Message block format

Header	<b>Message</b>	Check code	Delimiter
--------	----------------	------------	-----------

"Message block format" is allied to the "Message Type" in the "Header".

Refer to the section 4.1 "Header block format" for more detail.

### 1) Get current parameter

The controller sends this message when you want to get the status of the monitor.

For the status that you want to get, specify the "OP code page" and "OP code",

refer to "Appendix A. Operation code table".

"Message format" of the "Get current parameter" is as follows,

STX	OP code page		OP code		ETX
	Hi	Lo	Hi	Lo	

➤ Refer to section 5.1 "Get current parameter from a monitor." for more details.

### 2) Get Parameter reply

The monitor will reply with the status of the requested item specified by the controller in the "Get parameter message".

"Message format" of the "Get parameter reply" is as follows,

STX	Result		OP code page		OP code		Type		Max value			Current Value			ETX
	Hi	Lo	Hi	Lo	Hi	Lo	Hi	Lo	MSB		LSB	MSB		LSB	

➤ Refer to section 5.2 "Get parameter reply" for more details.

### 3) Set parameter

The controller sends this message to change a setting of the monitor.

Message format of the "Set parameter" is as follows,

STX	OP code page		OP code		Set Value			ETX
	Hi	Lo	Hi	Lo	MSB		LSB	

➤ Refer to section 5.3 "Set parameter" for more details.

### 4) Set Parameter reply

The monitor replies with this message for a confirmation of the "Set parameter message".

Message format of the "Set parameter reply" is as follows,

STX	Result		OP code page		OP code		Type		Max value			Requested setting Value			ETX
	Hi	Lo	Hi	Lo	Hi	Lo	Hi	Lo	MSB		LSB	MSB		LSB	

➤ Refer to section 5.4 "Set parameter reply" for more details.

### 5) Command

"Command message" format depends on each command.

Usually, this "command message" is used for some non-slider controls and some special operations, such as "Get timing report", "power control", etc. Refer to section 5.5 "Commands message" for

more details.

6) Command reply

The monitor replies to a query from the controller.

"Command reply message" format depends on each command.

Refer to section 5.5 "Commands message" for more details.

### 4.3 Check code

Header	Message	<b>Check code</b>	Delimiter
--------	---------	-------------------	-----------

Check code is the Block Check Code (BCC) between the Header and the End of Message except SOH.

			2 <sup>7</sup>	2 <sup>6</sup>	2 <sup>5</sup>	2 <sup>4</sup>	2 <sup>3</sup>	2 <sup>2</sup>	2 <sup>1</sup>	2 <sup>0</sup>
SOH	D <sub>0</sub>									
Reserved	D <sub>1</sub>									
Destination	D <sub>2</sub>									
Source	D <sub>3</sub>									
Type	D <sub>4</sub>									
Length(H)	D <sub>5</sub>									
Length(L)	D <sub>6</sub>									
STX	D <sub>7</sub>									
Data	D <sub>8</sub>									
ETX	D <sub>n</sub>									
Check code	D <sub>n+1</sub>	P	P	P	P	P	P	P	P	P

$$D_{n+1} = D_1 \text{ XOR } D_2 \text{ XOR } D_3 \text{ XOR } \dots \text{ XOR } D_n$$

XOR: Exclusive OR

Following is an example of a Check code (BCC) calculation.

Header						Message										Check code (BCC)	Delimiter	
SOH	Reserved	Destination Address	Source Address	Message type	Message length	STX	OP code page		OP code		Set Value				ETX			
01	30	41	30	45	30	41	02	30	30	31	30	30	30	36	34	03	77	0D
D <sub>0</sub>	D <sub>1</sub>	D <sub>2</sub>	D <sub>3</sub>	D <sub>4</sub>	D <sub>5</sub>	D <sub>6</sub>	D <sub>7</sub>	D <sub>8</sub>	D <sub>9</sub>	D <sub>10</sub>	D <sub>11</sub>	D <sub>12</sub>	D <sub>13</sub>	D <sub>14</sub>	D <sub>15</sub>	D <sub>16</sub>	D <sub>17</sub>	D <sub>18</sub>

$$\begin{aligned}
 \text{Check code (BCC) } D_{17} &= D_1 \text{ xor } D_2 \text{ xor } D_3 \text{ xor } \dots \text{ xor } D_{14} \text{ xor } D_{15} \text{ xor } D_{16} \\
 &= 30\text{h xor } 41\text{h xor } 30\text{h xor } 45\text{h xor } 30\text{h xor } 41\text{h} \\
 &\quad \text{xor } 02\text{h xor } 30\text{h xor } 30\text{h xor } 31\text{h xor } 30\text{h xor } 30\text{h} \\
 &\quad \text{xor } 30\text{h xor } 36\text{h xor } 34\text{h xor } 03\text{h} \\
 &= 77\text{h}
 \end{aligned}$$

#### 4.4 Delimiter

Header	Message	Check code	<b>Delimiter</b>
--------	---------	------------	------------------

Packet delimiter code; ASCII CR(0Dh).

## 5. Message type

### 5.1 Get current Parameter from a monitor.

STX	OP code page		OP code		ETX
	Hi	Lo	Hi	Lo	
1 <sup>st</sup>	2 <sup>nd</sup> -3 <sup>rd</sup>		4 <sup>th</sup> -5 <sup>th</sup>		6 <sup>th</sup>

Send this message when you want to get the status of a monitor.

For the status that you want to get, specify the "OP code page" the "OP code", refer to "Appendix A. Operation code table".

1<sup>st</sup>byte) STX: Start of Message

ASCII STX (02h)

2<sup>nd</sup>-3<sup>rd</sup>bytes) OP code page: Operation code page.

Specify the "OP code page" for the control which you want to get the status.

Refer to "Appendix A Operation code table" for each item.

OP code page data must be encoded to ASCII characters.

Ex.) The byte data 02h must be encoded to ASCII characters '0' and '2' (30h and 32h).

OP code page 02h -> OP code page (Hi) = ASCII '0' (30h)

OP code page (Lo) = ASCII '2' (32h)

Refer to Operation code table. (Appendix A)

4<sup>th</sup>-5<sup>th</sup>bytes) OP code: Operation code

Refer to "Appendix A Operation code table" for each item.

OP code data must be encoded to ASCII characters.

Ex.) The byte data 3Ah must be encoded to ASCII characters '3' and 'A' (33h and 41h).

OP code 3Ah -> OP code (Hi) = ASCII '3' (33h)

OP code (Lo) = ASCII 'A' (41h)

Refer to Operation code table.

6<sup>th</sup>byte) ETX: End of Message

ASCII ETX (03h)

## 5.2 "Get parameter" reply

STX	Result		OP code page		OP code		Type		Max value			Current Value			ETX
	Hi	Lo	Hi	Lo	Hi	Lo	Hi	Lo	MSB		LSB	MSB		LSB	
1 <sup>st</sup>	2 <sup>nd</sup> -3 <sup>rd</sup>		4 <sup>th</sup> -5 <sup>th</sup>		6 <sup>th</sup> -7 <sup>th</sup>		8 <sup>th</sup> -9 <sup>th</sup>		10 <sup>th</sup> -13 <sup>th</sup>			14 <sup>th</sup> -17 <sup>th</sup>			18 <sup>th</sup>

The monitor replies with a current value and the status of the requested item (operation code).

1<sup>st</sup>byte) STX: Start of Message

ASCII STX (02h)

2<sup>nd</sup>-3<sup>rd</sup>bytes) Result code.

These bytes indicate a result of the requested commands as follows,

00h: No Error.

01h: Unsupported operation with this monitor or unsupported operation under current condition.

This result code from the monitor is encoded to ASCII characters.

Result code is always 00h(No Error). Because monitor does not reply any command to the controller when monitor gets an unsupported command on Exx7.

Ex.) The byte data 00h is encoded to ASCII character '0' and '0' (30h and 30h).

4<sup>th</sup>-5<sup>th</sup>bytes) OP code page: Operation code page.

These bytes indicate a replying item's OP code page.

This returned value from the monitor is encoded to ASCII characters.

Ex.) The byte data 02h is encoded to ASCII character '0' and '2' (30h and 32h).

Refer to the operation code table.

6<sup>th</sup>-7<sup>th</sup>bytes) OP code: Operation code

These bytes indicate a replying item's OP code.

This returned value from the monitor is encoded to ASCII characters.

Refer to the operation code table.

Ex.) The byte data 1Ah is encoded to ASCII character '1' and 'A' (31h and 41h).

8<sup>th</sup>-9<sup>th</sup>bytes) Type: Operation type code

00h: Set parameter

Like the Auto Setup function which automatically changes the parameter.

This returned value from the monitor is encoded to ASCII characters.

Ex.) The byte data 01h is encoded to ASCII character '0' and '1' (30h and 31h).

10<sup>th</sup>-13<sup>th</sup>bytes) Max. value: Maximum value which monitor can accept. (16bits)

This returned value from the monitor is encoded to ASCII characters.

Ex.) '0','1','2' and '3' means 0123h (291)

14<sup>th</sup>-17<sup>th</sup>bytes) Current Value: (16bits)

This returned value from the monitor is encoded to ASCII characters.

Ex.) '0','1','2' and '3' means 0123h (291)

18<sup>th</sup>byte) ETX: End of Message

ASCII ETX (03h)

### 5.3 Set parameter

STX	OP code page		OP code		Set Value				ETX
	Hi	Lo	Hi	Lo	MSB			LSB	
1 <sup>st</sup>	2 <sup>nd</sup> -3 <sup>rd</sup>		4 <sup>th</sup> -5 <sup>th</sup>		6 <sup>th</sup> -9 <sup>th</sup>				10 <sup>th</sup>

Send this message to change monitor's adjustment and so on.

The controller requests a monitor to change value.

1<sup>st</sup>byte) STX: Start of Message

ASCII STX (02h)

2<sup>nd</sup>-3<sup>rd</sup>bytes) OP code page: Operation code page

This OP code page data must be encoded to ASCII characters.

Ex.) The byte data 02h must be encoded to ASCII '0' and '2' (30h and 32h).

Refer to the Operation code table.

4<sup>th</sup>-5<sup>th</sup>bytes) OP code: Operation code

This OP code data must be encoded to ASCII characters.

Ex.) OP code 1Ah -> OP code (Hi) = ASCII '1' (31h)

OP code (Lo) = ASCII 'A' (41h)

Refer to the Operation code table.

6<sup>th</sup>-9<sup>th</sup>bytes) Set value: (16bit)

This data must be encoded to ASCII characters.

Ex.) 0123h -> 1<sup>st</sup>(MSB) = ASCII '0' (30h)

2<sup>nd</sup> = ASCII '1' (31h)

3<sup>rd</sup> = ASCII '2' (32h)

4<sup>th</sup>(LSB) = ASCII '3' (33h)

➤ ASCII '0'-'9' and 'A'-'F' should be used for Set value.

10<sup>th</sup>byte) ETX: End of Message

ASCII ETX (03h)



## 5.4 "Set parameter" reply

STX	Result		OP code page		OP code		Type		Max value			Requested setting Value			ETX
	Hi	Lo	Hi	Lo	Hi	Lo	Hi	Lo	MSB		LSB	MSB		LSB	
1 <sup>st</sup>	2 <sup>nd</sup> -3 <sup>rd</sup>		4 <sup>th</sup> -5 <sup>th</sup>		6 <sup>th</sup> -7 <sup>th</sup>		8 <sup>th</sup> -9 <sup>th</sup>		10 <sup>th</sup> -13 <sup>th</sup>			14 <sup>th</sup> -17 <sup>th</sup>			18 <sup>th</sup>

The Monitor echoes back the parameter and status of the requested operation code.

1<sup>st</sup>byte) STX: Start of Message

ASCII STX (02h)

2<sup>nd</sup>-3<sup>rd</sup>bytes) Result code

ASCII '0' '0' (30h, 30h): No Error.

ASCII '0' '1' (30h, 31h): Unsupported operation with this monitor or unsupported operation under current condition.

4<sup>th</sup>-5<sup>th</sup>bytes) OP code page: Echoes back the Operation code page for confirmation.

Reply data from the monitor is encoded to ASCII characters.

Ex.) OP code page 02h -> OP code page = ASCII '0' and '2' (30h and 32h)

Refer to Operation code table.

6<sup>th</sup>-7<sup>th</sup>bytes) OP code: Echoes back the Operation code for confirmation.

Reply data from the monitor is encoded to ASCII characters.

Ex.) OP code 1Ah -> OP code (Hi) = ASCII '1' (31h)

OP code (Lo) = ASCII 'A' (41h)

Refer to Operation code table

8<sup>th</sup>-9<sup>th</sup>bytes) Type: Operation type code

ASCII '0' '0' (30h, 30h): Set parameter

Like Auto Setup function, that automatically changes the parameter.

10<sup>th</sup>-13<sup>th</sup>bytes) Max. value: Maximum value that monitor can accept. (16bits)

Reply data from the monitor is encoded to ASCII characters.

Ex.) '0' '1' '2' '3' means 0123h (291)

14<sup>th</sup>-17<sup>th</sup>bytes) Requested setting Value: Echoes back the parameter for confirmation. (16bits)

Reply data from the monitor is encoded to ASCII characters.

Ex.) '0' '1' '2' '3' means 0123h (291)

18<sup>th</sup>byte) ETX: End of Message

ASCII ETX (03h)

## 5.5 Commands

"Command message format" depends on each command. Some commands are shown with usage. Refer to section 7 to 25.

### 5.5.2 Get Timing Report and Timing reply.

The controller requests the monitor to report the displayed image timing.

STX	Command code		ETX
	'0'	'7'	

- Send "07"(30h, 37h) as Get Timing Report command.
- Complete "Get Timing Report" command packet as follows;

ASCII: 01h-30h-41h-30h-41h-30h-34h-02h-30h-37h-03h-CHK-0Dh

SOH-'0'-'A'-'0'-'A'-'0'-'4'-STX-'0'-'7'-ETX-CHK- CR

The monitor replies status as the following format;

STX	Command		SS		H Freq.				V Freq.				ETX
	'4'	'E'	Hi	Lo	MSB			LSB	MSB			LSB	

- SS: Timing status byte
    - Bit 7 = 1: Sync Frequency is out of range.
    - Bit 6 = 1: Unstable count
    - Bit 5-2 Reserved (Don't care)
    - Bit 1 1: Positive Horizontal sync polarity  
0: Negative Horizontal sync polarity.
    - Bit 0 1: Positive Vertical sync polarity.  
0: Negative Vertical sync polarity.
  - H Freq: Horizontal Frequency in unit 0.01kHz
  - V Freq: Vertical Frequency in unit 0.01Hz
- Ex.) When H Freq is '1'2'A'9' (31h, 32h, 41h, 39h), it means 47.77kHz.

### 5.5.3 NULL Message

STX	Command code		ETX
	'B'	'E'	

The NULL message returned from the monitor is used in the following cases;

- To tell the controller that the monitor does not have any answer to give to the host (not ready or not expected)
- A null message will be returned by the monitor if the "Start Proof of Play" command is sent and the monitor has already started Proof of Play.
- A null message will be returned by the monitor if the "Stop Proof of Play" command is sent and the monitor has not started Proof of Play.
- Complete "NULL Message" command packet as follows;  
01h-30h-30h-41h-42h-30h-34h-02h-42h-45h-03h-CHK-0Dh  
SOH-'0'-'0'-'A'-'B'-'0'-'4'-STX-'B'-'E'-ETX-CHK-CR

## IV. Control Commands

### 6. Typical procedure example

The following is a sample of procedures to control the monitor, these are examples of "Get parameter" and "Set parameter".

#### 6.1. How to change the "Backlight" setting.

Step 1. The controller requests the Monitor to reply with the current brightness setting and capability to support this operation. (Get parameter)

Header	Message	Check code	Delimiter
SOH-'0'-Monitor ID-'0'-'C'-'0'-'6'	STX-'0'-'0'-'1'-'0'-ETX	BCC	CR

#### Header

SOH (01h): Start of Header  
 '0' (30h): Reserved  
 Monitor ID: Specify the Monitor ID from which you want to get a value.  
 Ex.) If Monitor ID is '1', specify 'A'.  
 '0' (30h): Message sender is the controller.  
 'C' (43h): Message type is "Get parameter command".  
 '0'-'6' (30h, 36h): Message length is 6 bytes.

#### Message

STX (02h): Start of Message  
 '0'-'0' (30h, 30h): Operation code page number is 0.  
 '1'-'0' (31h, 30h): Operation code is 10h (in the OP code page 0).  
 ETX (03h): End of Message

#### Check code

BCC: Block Check Code  
 Refer to the section 4.3 "Check code" for a BCC calculation.

#### Delimiter

CR (0Dh): End of packet

Step 2. The monitor replies with current Backlight setting and capability to support this operation.

Header	Message	Check code	Delimiter
SOH-'0'-'0'-Monitor ID-'D'-'1'-'2'	STX-'0'-'0'-'0'-'0'-'1'-'0'-'0'-'0'-'0'-'0'-'6'-'4'-'0'-'0'-'3'-'2'-ETX	BCC	CR

#### Header

SOH (01h): Start of Header  
 '0' (30h): Reserved  
 '0' (30h): Message receiver is the controller.  
 Monitor ID: Indicate a replying Monitor ID.  
 Ex.) When this byte is set to 'A', the replying Monitor ID is '1'.  
 'D' (44h): Message Type is "Get parameter reply".  
 '1'-'2' (31h, 32h): Message length is 18 bytes.

#### Message

STX (02h): Start of Message  
 '0'-'0' (30h, 30h): Result code. No error.  
 '0'-'0' (30h, 30h): Operation code page number is 0.  
 '1'-'0' (31h, 30h): Operation code is 10h (in the page 0).  
 '0'-'0' (30h, 30h): This operation is "Set parameter" type.  
 '0'-'0'-'6'-'4' (30h, 30h, 36h, 34h): Backlight max value is 100(0064h).  
 '0'-'0'-'3'-'2' (30h, 30h, 33h, 32h): Current Backlight setting is 50(0032h).  
 ETX (03h): End of Message

Check code

BCC: Block Check Code

Refer to the section 4.3 "Check code" for a BCC calculation.

Delimiter

CR (0Dh): End of packet

Step 3. The controller request the monitor to change the Backlight setting

Header	Message	Check code	Delimiter
SOH-'0'-Monitor ID-'0'-'E'-'0'-'A'	STX-'0'-'0'-'1'-'0'-'0'-'0'-'5'-'0'-ETX	BCC	CR

Header

SOH (01h): Start of Header

'0' (30h): Reserved

Monitor ID: Specify the Monitor ID of which you want to change a setting.

Ex.) If Monitor ID is '1', specify 'A'.

'0' (30h): Message sender is the controller.

'E' (45h): Message Type is "Set parameter command".

'0'-'A' (30h, 41h): Message length is 10 bytes.

Message

STX (02h): Start of Message

'0'-'0' (30h, 30h): Operation code page number is 0.

'1'-'0' (31h, 30h): Operation code is 10h (in the page 0).

'0'-'0'-'5'-'0' (30h, 30h, 35h, 30h): Set Backlight setting 80(0050h).

ETX (03h): End of Message

Check code

BCC: Block Check Code

Refer to the section 4.3 "Check code" for a BCC calculation.

Delimiter

CR (0Dh): End of packet

Step 4. The monitor replies with a message for confirmation.

Header	Message	Check code	Delimiter
SOH-'0'-'0'- Monitor ID - 'F'-'1'-'2'	STX-'0'-'0'-'0'-'0'-'1'-'0'-'0'-'0'-'0'-'0'-'6'-'4'-'0'-'0'-'5'-'0'-ETX	BCC	CR

Header

SOH (01h): Start of Header

'0' (30h): Reserved

'0' (30h): Message receiver is the controller.

Monitor ID: Indicate a replying Monitor ID.

Ex.) When this byte is set to 'A', the replying Monitor ID is '1'.

'F' (46h): Message Type is "Set parameter reply".

'1'-'2' (31h, 32h): Message length is 18 bytes.

Message

STX (02h): Start of Message

'0'-'0' (30h, 30h): Result code. No error.

'0'-'0' (30h, 30h): Operation code page number is 0.

'1'-'0' (31h, 30h): Operation code is 10h (in the page 0).

'0'-'0' (30h, 30h): This operation is "Set parameter" type.

'0'-'0'-'6'-'4' (30h, 30h, 36h, 34h): Backlight max value is 100(0064h).

'0'-'0'-'5'-'0' (30h, 30h, 35h, 30h): Received a Backlight setting was 80(0050h) .

ETX (03h): End of Message

Check code

BCC: Block Check Code

Refer to the section 4.3 "Check code" for a BCC calculation.

Delimiter

CR (0Dh): End of packet

- Repeat Step 1 and Step 2, if you need to check the Backlight setting. (Recommended)

## 6.2. Operation Code (OP code) Table

Item	OP code page	OP code	Parameters	Remarks
COLOR TEMPERATURE	00h	0Ch	00h: No mean 23h: Warm 3Fh: Normal 5Ah: Cool	
	00H	14H	00h: No mean 02h: NATIVE 0Bh: Custom (Read only)	When setting to Native, should use this OP code
Clock	00h	0Eh	0:   Max	
Brightness	00h	10h	0: dark   100(64h): bright	
Contrast	00h	12h	0: low   100(64h): high	
Auto Set Up	00h	1Eh	0: No mean 1: Execute	
Horizontal Position	00h	20h	0: Left side   Max.: Right side	
Vertical Position	00h	30h	0: Bottom side   Max.: Top side	
Clock Phase	00h	3Eh	0:   Max.	
Input Source	00h	60h	0: No mean 1: VGA 5: VIDEO 9: Tuner (TV tuner model only) 12(0Ch): COMPONENT 17(11h): HDMI1 18(12h): HDMI2 130(82h): HDMI3 135(87h): USB	
Audio Speaker Volume Adjust	00h	62h	0: whisper   100(64h): loud	
Language select	00h	68h	00h: No mean 01h: English 02h: German 03h: French 04h: Spanish 05h: Japanese 06h: Italian 09h: Russian 0Eh: Chinese 0Fh: Czech	In case TV tuner model, only English, French and Spanish can be selected.
Sharpness	00h	8Ch	0: dull   24(18h): sharp	
Color	02h	1Fh	0: pale   100(64h): deep	
TV-CHANNEL UP/DOWN	00h	8Bh	0: No mean 1: UP 2: DOWN	This operation requires supported TV tuner model.

Item	OP code page	OP code	Parameters	Remarks
MUTE	00h	8Dh	0: UNMUTE (Set only) 1: MUTE 2: UNMUTE	
TREBLE	00h	8Fh	0: Min.   50:(Center)   100(64h): Max.	
HUE	00h	90h	0: purplish   100(64h): greenish	
BASS	00h	91h	0: Min.   50:(Center)   100(64h): Max.	
BRIGHTNESS	00h	92h	0: dark   100(64h): bright	
BALANCE	00h	93h	0: Left   30(1Eh):(Center)   60(3Ch): Right	
Key Lock	00h	FBH	0: No mean 1: UNLOCK 2: ALL LOCK	
MENU DISPLAY TIME	00h	FCh	0-1: Do not set. 2: 10s 3: 15s   48(30h): 240s	5sec/step
PICTURE MODE	02h	1Ah	0 : No operate 4 : Standard 5 : Theater 8 : Custom 23(17h) : Dynamic 24(18h) : Energy Saving 25(19h) : Game 26(1Ah) : HDR Dynamic (except for E327) 27(1Bh) : HDR Video (except for E327)	
NOISE REDUCTION	02h	26h	0: Off   3: High	OP code page 02 OP code 20h also works as same.
MTS	02h	2CH	0 : No mean 2 : SAP 4 : stereo 5 : mono	
MONITOR ID	02h	3Eh	1-100:ID	
IR Control	02h	3FH	0 : No mean 1 : Normal 4 : Lock (off)	
Input Detect	02h	40h	0 : First detect 2 : None 4 : Custom detect	
Size	02h	70H	0 : No mean 1 : Normal 2 : Full 3 : Wide 4 : Zoom 10(0Ah) : Cinema 11(0Bh) : Auto	



Item	OP code page	OP code	Parameters	Remarks
Adaptive Contrast	02h	8DH	0 : No mean 1 : Off 2 : On	
Gamma	02h	E8h	0: No mean 200(C8h): Low 220(DCh): Mid 240(F0h): High	
Custom Detect Priority 1	10h	2Eh	0: No mean 1: VGA(RGB) 5: VIDEO	
Custom Detect Priority 2	10h	2Fh	12(0Ch): COMPONENT 17(11h): HDMI1 18(12h): HDMI2	
Custom Detect Priority 3	10h	30h	130(82h): HDMI3	
Closed Caption	10h	84H	0 : No mean 1 : Off 2 : CC1 3 : CC2 4 : CC3 5 : CC4 6 : TT1 7 : TT2 8 : TT3 9 : TT4	
Digital Closed Caption	10h	A1h	0: No Mean 1: OFF 2: CS1 3: CS2 4: CS3 5: CS4 6: CS5 7: CS6	
Sound mode	10h	B2h	0: No mean 1: Standard 2: Movie 3: Music 4: News 5: Custom	
Audio Language	10h	B3h	0: No mean 2: English 3: French 10(0Ah): Spanish	
Light Sensor	10h	C8h	0: No mean 1: OFF, 2: ON 3: No mean	
BACKLIGHT DIMMING	11h	4Eh	0: No mean 1: OFF 2: Low 4: High	
USB POWER	11h	75h	0: No mean 1: ON 3: OFF	
Speaker Select	11h	BAh	0: No mean 1: OFF 2: ON 3: AUTO	

## 7. Power control procedure

### 7.1 Power status read

1) The controller requests the monitor to reply a current power status.

Header	Message	Check code	Delimiter
SOH-'0'-Monitor ID-'0'-'A'-'0'-'6'	STX-'0'-'1'-'D'-'6'-ETX	BCC	CR

#### Header

SOH (01h): Start of Header  
 '0' (30h): Reserved  
 Monitor ID: Specify the Monitor ID from which you want to get status.  
 Ex.) If Monitor ID is '1', specify 'A'.  
 '0' (30h): Message sender is the controller.  
 'A' (41h): Message Type is "Command".  
 '0'-'6' (30h, 36h): Message length is 6 bytes.

#### Message

STX (02h): Start of Message  
 '0'-'1'-'D'-'6': Get power status command.  
 ETX (03h): End of Message

#### Check code

BCC: Block Check Code  
 Refer to the section 4.3 "Check code" for a BCC calculation.

#### Delimiter

CR (0Dh): End of packet

2) The monitor returns with the current power status.

Header	Message	Check code	Delimiter
SOH-'0'-'0'-Monitor ID-'B'-'1'-'2'	STX-'0'-'2'-'0'-'0'-'D'-'6'-'0'-'0'-'0'-'0'-'4'-'0'-'0'-'0'-'1'-ETX	BCC	CR

#### Header

SOH (01h): Start of Header  
 '0' (30h): Reserved  
 '0' (30h): Message receiver is the controller.  
 Monitor ID: Indicate a replying Monitor ID.  
 Ex.) When this byte is set to 'A', the replying Monitor ID is '1'.  
 'B' (42h): Message Type is "Command reply".  
 '1'-'2' (31h, 32h): Message length is 18 bytes.

#### Message

STX (02h): Start of Message  
 '0'-'2' (30h, 32h): Reserved data  
 '0'-'0' (30h, 30h): Result code  
 00: No Error.  
 01: Unsupported.  
 'D'-'6' (44h, 36h): Display power mode code  
 '0'-'0' (30h, 30h): Parameter type code is "Set parameter".  
 '0'-'0'-'0'-'4' (30h, 30h, 30h, 34h): Power mode is 4 types.  
 '0'-'0'-'0'-'1' (30h, 30h, 30h, 31h): Current power mode  
 <Status>  
 0001: ON  
 0002: No mean  
 0003: power save  
 0004: OFF (same as IR power off)  
 ETX (03h): End of Message

#### Check code

BCC: Block Check Code

Refer to the section 4.3 "Check code" for a BCC calculation.

Delimiter

CR (0Dh): End of packet

## 7.2 Power control

1) The controller requests the monitor to control monitor power.

Header	Message	Check code	Delimiter
SOH-'0'-Monitor ID-'0'-'A'-'0'-'C'	STX-'C'-'2'-'0'-'3'-'D'-'6'-'0'-'0'-'0'-'1'-ETX	BCC	CR

### Header

SOH (01h): Start of Header  
 '0' (30h): Reserved  
 Monitor ID: Specify the Monitor ID which you want to change a setting.  
 Ex.) If Monitor ID is '1', specify 'A'.  
 '0' (30h): Message sender is the controller.  
 'A' (41h): Message type is "Command".  
 '0'-'C' (30h, 43h): Message length is 12 bytes.

### Message

STX (02h): Start of Message  
 'C'-'2'-'0'-'3'-'D'-'6' (43h, 32h, 30h, 33h, 44h, 36h): power control command  
 '0'-'0'-'0'-'1' (30h, 30h, 30h, 31h): Power mode  
     0001: ON  
     0002, 0003: Do not set.  
     0004: OFF (same as the power off by IR)

ETX (03h): End of Message

### Check code

BCC: Block Check Code  
 Refer to the section 4.3 "Check code" for a BCC calculation.

### Delimiter

CR (0Dh): End of packet

2) The monitor replies a data for confirmation.

Header	Message	Check code	Delimiter
SOH-'0'-'0'-'0'-'0'-'B'-'0'-'E'	STX-'0'-'0'-'0'-'C'-'2'-'0'-'3'-'D'-'6'-'0'-'0'-'0'-'1'-ETX	BCC	CR

### Header

SOH (01h): Start of Header  
 '0' (30h): Reserved  
 '0' (30h): Message receiver is the controller.  
 Monitor ID: Indicate a replying Monitor ID.  
 Ex.) When this byte is set to 'A', the replying Monitor ID is '1'.  
 'B' (42h): Message type is "Command reply".  
 'N'-'N': Message length  
 Note.) The maximum data length that can be written to the monitor at a time is 32bytes.  
 Ex.) The byte data 20h is encoded as ASCII characters '2' and '0' (32h and 30h).

### Message

STX (02h): Start of Message  
 '0'-'0' (30h, 30h): Result code. No error.  
 'C'-'2', '0'-'3'-'D'-'6' (43h, 32h, 30h, 33h, 44h, 36h): power control reply command  
 > The monitor replies same as power control command to the controller.  
 '0'-'0'-'0'-'1' (30h, 30h, 30h, 31h): Power mode  
     0001: ON  
     0002, 0003: Do not set.  
     0004: OFF (same as the power off by IR)

ETX (03h): End of Message

Check code

BCC: Block Check Code

Refer to the section 4.3 "Check code" for a BCC calculation.

Delimiter

CR (0Dh): End of packet

## 10. Get Timing Report

### 10.1 Get Timing Report and Timing reply.

The controller requests the monitor to report the displayed image timing.

- 1) The controller requests the monitor to get timing report.

Header	Message	Check code	Delimiter
SOH-'0'-Monitor ID-'0'-'A'-'0'-'4'	STX-'0'-'7'-ETX	BCC	CR

#### Header

SOH (01h): Start of Header  
'0' (30h): Reserved  
Monitor ID: Specify the Monitor ID from which you want to get status.  
Ex.) If Monitor ID is '1', specify 'A'.  
'0' (30h): Message sender is the controller.  
  
'A' (41h): Message Type is "Command".  
'0'-'4' (30h, 34h): Message length is 4 bytes.

#### Message

STX (02h): Start of Message  
'0'-'7' (30h, 37h): Get Timing Report command.  
ETX (03h): End of Message

#### Check code

BCC: Block Check Code  
Refer to the section 4.3 "Check code" for a BCC calculation.

#### Delimiter

CR (0Dh): End of packet

Complete "Get Timing Report" command packet as follows;

ASCII: 01h-30h-41h-30h-41h-30h-34h-02h-30h-37h-03h-CHK-0Dh  
SOH-'0'-'A'-'0'-'A'-'0'-'4'-STX-'0'-'7'-ETX-CHK-CR

- 2) The monitor replies Timing report to the controller.

Header	Message	Check code	Delimiter
SOH-'0'-'0'-Monitor ID-'B'-'0'-'E'	STX-'4'-'E'-SS-H Freq-V Freq-ETX	BCC	CR

#### Header

SOH (01h): Start of Header  
'0' (30h): Reserved  
'0' (30h): Message receiver is the controller.  
Monitor ID: Indicate a replying Monitor ID.  
Ex.) When this byte is set to 'A', the replying Monitor ID is '1'.  
'B' (42h): Message type is "Command reply".  
'0'-'E'(30h, 45h): Message length

#### Message

STX (02h): Start of Message  
'4'-'E' (34h, 45h): Timing reply command  
SS: Timing status byte  
Bit 7 = 1: Sync Frequency is out of range.  
Bit 6 = 1: Unstable count  
Bit 5-2 Reserved (Don't care)  
Bit 1 1: Positive Horizontal sync polarity  
0: Negative Horizontal sync polarity.  
Bit 0 1: Positive Vertical sync polarity.  
0: Negative Vertical sync polarity.

H Freq: Horizontal Frequency in unit 0.01kHz

V Freq: Vertical Frequency in unit 0.01Hz

Ex.) When H Freq is '1'2'A'9' (31h, 32h, 41h, 39h), it means 47.77kHz.

Check code

BCC: Block Check Code

Refer to the section 4.3 "Check code" for a BCC calculation.

Delimiter

CR (0Dh): End of packet

## 11. Serial No. & Model Name Read

### 11.1 Serial No. Read

This command is used in order to read a serial number.

- 1) The controller requests the monitor to read a serial number.

Header	Message	Check code	Delimiter
SOH-'0'-Monitor ID-'0'-'A'-'0'-'6'	STX-'C'-'2'-'1'-'6'-ETX	BCC	CR

#### Header

SOH (01h): Start of Header  
 '0' (30h): Reserved  
 Monitor ID: Specify the Monitor ID which you want to get serial number.  
 Ex.) If Monitor ID is '1', specify 'A'.  
 '0' (30h): Message sender is the controller.  
 'A' (41h): Message type is "Command".  
 '0'-'6'(30h, 36h): Message length

#### Message

STX (02h): Start of Message  
 'C'-'2'-'1'-'6' (43h, 32h, 31h, 36h): Serial No. command  
 ETX (03h): End of Message

#### Check code

BCC: Block Check Code  
 Refer to the section 4.3 "Check code" for a BCC calculation.

#### Delimiter

CR (0Dh): End of packet

- 2) The monitor replies the serial No. data to the controller.

Header	Message	Check code	Delimiter
SOH-'0'-'0'-Monitor ID-'B'-'N'-N	STX-'C'-'3'-'1'-'6'-Data(0)-Data(1)---Data(n)-ETX	BCC	CR

#### Header

SOH (01h): Start of Header  
 '0' (30h): Reserved  
 '0' (30h): Message receiver is the controller.  
 Monitor ID: Indicate a replying Monitor ID.  
 Ex.) When this byte is set to 'A', the replying Monitor ID is '1'.  
 'B' (42h): Message type is "Command reply".  
 N-N: Message length  
 Note.) The maximum data length that can be returned from the monitor at a time is 32bytes.  
 Ex.) The byte data 20h is encoded as ASCII characters '2' and '0' (32h and 30h).

#### Message

STX (02h): Start of Message  
 'C'-'3'-'1'-'6' (43h, 33h, 31h, 36h): Serial No. reply command  
 Data(0)-Data(1)---Data(n):Serial Number  
 > The byte data 20h is encoded as ASCII characters '2' and '0' (32h and 30h).  
 Ex.) For example when receiving Serial Number data 33h 31h 33h 32h 33h 33h 33h 34h  
 Step1: Serial Number data is encoded as character string.  
 Example:  
 33h 31h 33h 32h 33h 33h 33h 34h -> '3','1','3','2','3','3','3','4'  
 Step2: Decode pairs of ASCII characters to hexadecimal values.  
 Example:  
 '3','1','3','2','3','3','3','4' -> 31h 32h 33h 34h  
 Step3: Byte data represents the ASCII string data.  
 Example:  
 31h 32h 33h 34h -> "1234"  
 Result: Serial Number is "1234".  
 Note: No null termination character is sent.



ETX (03h): End of Message

Check code

BCC: Block Check Code

Refer to the section 4.3 "Check code" for a BCC calculation.

Delimiter

CR (0Dh): End of packet

## 11.2 Model Name Read

This command is used in order to read the Model Name.

1) The controller requests the monitor to read Model Name.

Header	Message	Check code	Delimiter
SOH-'0'-Monitor ID-'0'-'A'-'0'-'6'	STX-'C'-'2'-'1'-'7'-ETX	BCC	CR

### Header

SOH (01h): Start of Header  
 '0' (30h): Reserved  
 Monitor ID: Specify the Monitor ID which you want to get Model Name.  
 Ex.) If Monitor ID is '1', specify 'A'.  
 '0' (30h): Message sender is the controller.  
 'A' (41h): Message type is "Command".  
 '0'-'6'(30h, 36h): Message length

### Message

STX (02h): Start of Message  
 'C'-'2'-'1'-'7' (43h, 32h, 31h, 37h): Model Name command  
 ETX (03h): End of Message

### Check code

BCC: Block Check Code  
 Refer to the section 4.3 "Check code" for a BCC calculation.

### Delimiter

CR (0Dh): End of packet

2) The monitor replies the model name data to the controller.

Header	Message	Check code	Delimiter
SOH-'0'-'0'-Monitor ID-'B'-'N'-N	STX-'C'-'3'-'1'-'7'-Data(0) -Data(1)----Data(n)-ETX	BCC	CR

### Header

SOH (01h): Start of Header  
 '0' (30h): Reserved  
 '0' (30h): Message receiver is the controller.  
 Monitor ID: Indicate a replying Monitor ID.  
 Ex.) When this byte is set to 'A', the replying Monitor ID is '1'.  
 'B' (42h): Message type is "Command reply".  
 N-N: Message length  
 Note.) The maximum data length that can be returned from the monitor at a time is 32bytes.  
 Ex.) The byte data 20h is encoded as ASCII characters '2' and '0' (32h and 30h).

### Message

STX (02h): Start of Message  
 'C'-'3'-'1'-'7' (43h, 33h, 31h, 37h): Model Name reply Command  
 Data(0) -Data(1)----Data(n):Model name  
 > The byte data 20h is encoded as ASCII characters '2' and '0' (32h and 30h).  
 Ex.) For example when receiving Model Name data 35h 30h 33h 34h 33h 30h 33h 33h  
 Step1: Model Name data is encoded character string.  
 Example:  
 34h 35h 33h 33h 33h 32h 33h 37h -> '4','5','3','3','3','2','3','7'  
 Step2: Decode pairs of ASCII characters to hexadecimal values.  
 Example:  
 '4','5','3','3','3','2','3','7' -> 45h 33h 32h 37h  
 Step3: Byte data represents the ASCII string data.  
 Example:  
 45h 33h 32h 37h -> "E327"  
 Result: Model Name is "E327".  
 Note: No null termination character is sent.  
 ETX (03h): End of Message

Check code

BCC: Block Check Code

Refer to the section 4.3 "Check code" for a BCC calculation.

Delimiter

CR (0Dh): End of packet

## 12. Firmware Version

### 12.1 Firmware Version Read

This command is used in order to read a firmware version.

- 1) The controller requests the monitor to reply a firmware version.

Header	Message	Check code	Delimiter
SOH-'0'-Monitor ID-'0'-'A'-'0'-'8'	STX-'C'-'A'-'0'-'2'-TY-ETX	BCC	CR

#### Header

SOH (01h): Start of Header  
'0' (30h): Reserved  
Monitor ID: Specify the Monitor ID of which you want to change a setting.  
Ex.) If Monitor ID is '1', specify 'A'.  
'0' (30h): Message sender is the controller.  
'A' (41h): Message type is "Command".  
'0'-'8'(30h, 38h): Message length (8bytes)

#### Message

STX (02h): Start of Message  
'C'-'A'-'0'-'2' (43h, 41h, 30h, 32h): Firmware Version Command  
TY: Firmware Type  
Firmware: 00h (30h, 30h)  
LAN FW: 01h (30h, 31h)  
ETX (03h): End of Message

#### Check code

BCC: Block Check Code  
Refer to the section 4.3 "Check code" for a BCC calculation.

#### Delimiter

CR (0Dh): End of packet

- 2) The monitor replies a firmware version to the controller.

Header	Message	Check code	Delimiter
SOH-'0'-Monitor ID-'0'-'B'-'N'-'N'	STX-'C'-'B'-'0'-'2'-ST-TY-Data(0) -Data(1)-----Data(n)-ETX	BCC	CR

#### Header

SOH (01h): Start of Header  
'0' (30h): Reserved  
'0' (30h): Message receiver is the controller.  
Monitor ID: Indicate a replying Monitor ID.  
Ex.) When this byte is set to 'A', replying monitor's ID is '1'.  
'B' (42h): Message type is "Command reply".  
N-N: Message length  
Note.) The maximum data length that can be returned from the monitor at a time is 32bytes.

#### Message

STX (02h): Start of Message  
'C'-'B'-'0'-'2' (43h, 42h, 30h, 32h): Firmware Version Read reply  
ST: Error Status  
No Error: 00h (30h, 30h)  
Error : 01h (30h, 31h)  
TY: Firmware Type  
Firmware: 00h (30h, 30h)  
LAN FW: 01h (30h, 31h)  
Data(0)-Data(1)----Data(n): Version Number

Check code

BCC: Block Check Code

Refer to the section 4.3 "Check code" for a BCC calculation.

Delimiter

CR (0Dh): End of packet

## 13. LAN MAC Address

### 13.1 LAN MAC Address Read

This command is used in order to read the MAC Address.

- 1) The controller requests the monitor to read MAC Address

Header	Message	Check code	Delimiter
SOH-'0'-Monitor ID-'0'-'A'-'0'-'8'	STX-'C'-'2'-'2'-'A'-'0'-'2'-ETX	BCC	CR

#### Header

SOH (01h) : Start of Header  
 '0' (30h) : Reserved  
 Monitor ID: Specify the Monitor ID from which you want to get status.  
 Ex.) If Monitor ID is '1', specify 'A'.  
 '0' (30h) : Message sender is the controller.  
 'A' (41h) : Message Type is "Command".  
 '0'-'8' (30h, 38h) : Message length is 8 bytes.

#### Message

STX (02h) : Start of Message  
 'C'-'2'-'2'-'A': LAN read command.  
 '0'-'2': MAC Address  
 ETX (03h) : End of Message

#### Check code

BCC: Block Check Code  
 Refer to the section 4.3 "Check code" for a BCC calculation.

#### Delimiter

CR (0Dh) : End of packet

- 2) The monitor replies MAC Address to the controller.

Header	Message	Check code	Delimiter
SOH-'0'-'0'-Monitor ID-'B'-LN(H)-LN(L)	STX-'C'-'3'-'2'-'A'-RC-'0'-'2'-IPV-MAC(0)-...-MAC(n)-ETX	BCC	CR

#### Header

SOH (01h) : Start of Header  
 '0' (30h) : Reserved  
 '0' (30h) : Message receiver is the controller.  
 Monitor ID: Indicate a replying Monitor ID.  
 Ex.) When this byte is set to 'A', the replying Monitor ID is '1'.  
 'B' (42h) : Message Type is "Command reply".  
 LN(H)-LN(L) : Message length (byte length), from STX to ETX

#### Message

STX(02h):Start of Message  
 'C'-'3'-'2'-'A': LAN read reply command.  
 RC: Reply result Code  
 '0'-'0' (30h, 30h): Normal  
 'F'-'F' (46h, 46h): Abnormal  
 '0'-'2': MAC Address  
 IPV: IPv4 or IPv6  
 '0'-'4' (30h, 34h): IPv4  
 '0'-'6' (30h, 36h): IPv6  
 MAC(0-n): MAC Address  
 In the case of IPv4 -> n = 4  
 ETX (03h) : End of Message

Check code

BCC: Block Check Code

Refer to the section 4.3 "Check code" for a BCC calculation.

Delimiter

CR (0Dh): End of packet

## 14. Direct TV Channel Read & Write

When DTV unit (Option unit) is installed, channel settings is read and write directly.

### 14.1 Direct TV Channel Read & Reply

- 1) The controller requests the monitor to read channel information.

Header	Message	Check code	Delimiter
SOH-'0'-Monitor ID-'0'-'A'-'0'-'6'	STX-'C'-'2'-'2'-'C'-ETX	BCC	CR

#### Header

SOH (01h): Start of Header

'0' (30h): Reserved

Monitor ID: Specify the Monitor ID which you want to get Model Name.

Ex.) If Monitor ID is '1', specify 'A'.

'0' (30h): Message sender is the controller.

'A' (41h): Message type is "Command".

'0'-'6'(30h, 36h): Message length

#### Message

STX (02h): Start of Message

'C'-'2'-'2'-'C' (43h, 32h, 32h, 43h): Direct TV Channel Read command

ETX (03h): End of Message

#### Check code

BCC: Block Check Code

Refer to the section 4.3 "Check code" for a BCC calculation.

#### Delimiter

CR (0Dh): End of packet

- 2) The monitor replies the result to the controller.

Header	Message	Check code	Delimiter
SOH-'0'-'0'-Monitor ID-'B'-'1'-'2'	STX-'C'-'3'-'2'-'C'-MajorCH-MinorCH-ETX	BCC	CR

#### Header

SOH (01h): Start of Header

'0' (30h): Reserved

'0' (30h): Message receiver is the controller.

Monitor ID: Indicate a replying Monitor ID.

Ex.) When this byte is set to 'A', the replying Monitor ID is '1'.

'B' (42h): Message type is "Command reply".

'1'-'2'(31h, 32h): Message length = 18bytes

#### Message

STX (02h): Start of Message

'C'-'3'-'2'-'C' (43h, 33h, 32h, 43h): Direct TV Channel read reply command

MajorCH: Major Channel (0000000h - FFFFFFFh),

'0'-'0'-'0'-'0'-'0'-'0'-'0'-'0' - 'F'-'F'-'F'-'F'-'F'-'F'-'F'-'F'

MinorCH: Minor Channel (0000h - FFFFh),

'0'-'0'-'0'-'0' - 'F'-'F'-'F'-'F'

ETX (03h): End of Message

#### Check code

BCC: Block Check Code

Refer to the section 4.3 "Check code" for a BCC calculation.

#### Delimiter

CR (0Dh): End of packet



## 14.2 Direct TV Channel Write & Reply

1) The controller requests the monitor to write channel information.

Header	Message	Check code	Delimiter
SOH-'0'-Monitor ID- '0'-'A'-'1'-'2'	STX-'C'-'2'-'2'-'D'- MajorCH-MinorCH-ETX	BCC	CR

### Header

SOH (01h): Start of Header  
 '0' (30h): Reserved  
 Monitor ID: Specify the Monitor ID which you want to get Model Name.  
 Ex.) If Monitor ID is '1', specify 'A'.  
 '0' (30h): Message sender is the controller.  
 'A' (41h): Message type is "Command".  
 '1'-'2'(31h, 32h): Message length = 18bytes

### Message

STX (02h): Start of Message  
 'C'-'2'-'2'-'D' (43h, 32h, 32h, 44h): Direct TV Channel write command  
 MajorCH: Major Channel (00000000h - FFFFFFFFh),  
 '0'-'0'-'0'-'0'-'0'-'0'-'0'-'0' - 'F'-'F'-'F'-'F'-'F'-'F'-'F'-'F'  
 MinorCH: Minor Channel (0000h - FFFFh),  
 '0'-'0'-'0'-'0' - 'F'-'F'-'F'-'F'  
 ETX (03h): End of Message

### Check code

BCC: Block Check Code  
 Refer to the section 4.3 "Check code" for a BCC calculation.

### Delimiter

CR (0Dh): End of packet

2) The monitor replies the result to the controller.

Header	Message	Check code	Delimiter
SOH-'0'-'0'-Monitor ID- 'B'-'1'-'2'	STX-'C'-'3'-'2'-'D'- MajorCH-MinorCH-ETX	BCC	CR

### Header

SOH (01h): Start of Header  
 '0' (30h): Reserved  
 '0' (30h): Message receiver is the controller.  
 Monitor ID: Indicate a replying Monitor ID.  
 Ex.) When this byte is set to 'A', the replying Monitor ID is '1'.  
 'B' (42h): Message type is "Command reply".  
 '1'-'2'(31h, 32h): Message length = 18bytes

### Message

STX (02h): Start of Message  
 'C'-'3'-'2'-'D' (43h, 33h, 32h, 43h): Direct TV Channel write reply command  
 MajorCH: Major Channel (00000000h - FFFFFFFFh),  
 '0'-'0'-'0'-'0'-'0'-'0'-'0'-'0' - 'F'-'F'-'F'-'F'-'F'-'F'-'F'-'F'  
 MinorCH: Minor Channel (0000h - FFFFh),  
 '0'-'0'-'0'-'0' - 'F'-'F'-'F'-'F'  
 ETX (03h): End of Message

### Check code

BCC: Block Check Code  
 Refer to the section 4.3 "Check code" for a BCC calculation.

### Delimiter

CR (0Dh): End of packet

## 15. Input Name

### 15.1 Input Name Read

This command is used in order to read the setting of Input Name.

- 1) The controller requests the monitor to reply Input Name setting.

Header	Message	Check code	Delimiter
SOH-'0'-Monitor ID-'0'-'A'-'0'-'8'	STX-'C'-'A'-'0'-'4'-'0'-'0'-ETX	BCC	CR

#### Header

SOH (01h): Start of Header  
 '0' (30h): Reserved  
 Monitor ID: Specify the Monitor ID of which you want to change a setting.  
 Ex.) If Monitor ID is '1', specify 'A'.  
 '0' (30h): Message sender is the controller.  
 'A' (41h): Message type is "Command".  
 '0'-'8'(30h, 38h): Message length (8bytes)

#### Message

STX (02h): Start of Message  
 'C'-'A'-'0'-'4' (43h, 41h, 30h, 34h): Input Name Command  
 '0'-'0' (30h, 30h): Read  
 ETX (03h): End of Message

#### Check code

BCC: Block Check Code  
 Refer to the section 4.3 "Check code" for a BCC calculation.

#### Delimiter

CR (0Dh): End of packet

- 2) The monitor replies Input Name to the controller.

Header	Message	Check code	Delimiter
SOH-'0'-'0'-Monitor ID-'B'-LN(H)-LN(L)	STX-'C'-'B'-'0'-'4'-'0'-'0'-Data(0)-Data(1)-Data(2)- --- -Data(n)-ETX	BCC	CR

#### Header

SOH (01h): Start of Header  
 '0' (30h): Reserved  
 '0' (30h): Message receiver is the controller.  
 Monitor ID: Indicate a replying Monitor ID.  
 Ex.) When this byte is set to 'A', replying monitor's ID is '1'.  
 'B' (42h): Message type is "Command reply".  
 LN(H)-LN(L): Message length (byte length), from STX to ETX  
 Ex.) The byte data 20h is encoded as ASCII characters '2' and '0' (32h and 30h).

#### Message

STX (02h): Start of Message  
 'C'-'B'-'0'-'4' (43h, 42h, 30h, 34h): Input Name command reply  
 '0'-'0' (30h, 30h): Read  
 Data(n) : Input name \*n = Max 14  
 > The byte data 20h is encoded as ASCII characters '2' and '0' (32h and 30h).  
 Ex.) For example when receiving Data(n) of 35h 36h 34h 37h 34h 31h  
 Step1: Input Name data is encoded as character code.  
 Example:  
 35h 36h 34h 37h 34h 31h -> '5'-'6'-'4'-'7'-'4'-'1'  
 Step2: Decode pairs of ASCII characters to hexadecimal values.  
 Example:  
 '5'-'6'-'4'-'7'-'4'-'1' -> 56h 47h 41h  
 Step3: Byte data represents the ASCII string data.

Example:

56h 47h 41h -> "VGA"

Result: Input Name is "VGA".

Note: No null termination character is sent.

ETX (03h): End of Message

Check code

BCC: Block Check Code

Refer to the section 4.3 "Check code" for a BCC calculation.

Delimiter

CR (0Dh): End of packet

## 15.2 Input Name Write

This command is used in order to write the setting of Input Name.

- 1) The controller requests the monitor to write Input Name.

Header	Message	Check code	Delimiter
SOH-'0'-Monitor ID-'0'-'A'- LN(H)-LN(L)	STX-'C'-'A'-'0'-'4'-'0'-'1'-Data(0)-Data(1)-Data(2)- --- -Data(n)-ETX	BCC	CR

### Header

SOH (01h): Start of Header  
 '0' (30h): Reserved  
 Monitor ID: Specify the Monitor ID of which you want to change a setting.  
 Ex.) If Monitor ID is '1', specify 'A'.  
 '0' (30h): Message sender is the controller.  
 'A' (41h): Message type is "Command".  
 LN(H)-LN(L): Message length (byte length), from STX to ETX  
 Ex.) The byte data 20h is encoded as ASCII characters '2' and '0' (32h and 30h).

### Message

STX (02h): Start of Message  
 'C'-'A'-'0'-'4' (43h, 41h, 30h, 34h): Input name Command  
 '0'-'1' (30h, 31h): Write  
 Data(n) : Input name \*n = Max 14  
 > The byte data 20h is encoded as ASCII characters '2' and '0' (32h and 30h).  
 Ex.) In the case of Input Name "VGA"  
 Step1: Input Name data is handled as character code.  
 Example:  
 "VGA" -> 56h 47h 41h (ASCII)  
 Step2: The hexadecimal value of each original character is encoded as two ASCII characters representing the value.  
 Example:  
 56h 47h 41h -> '5'-'6'-'4'-'7'-'4'-'1'  
 Result: The following data is assigned to Data(n).  
 35h 36h 34h 37h 34h 31h  
 ETX (03h): End of Message

### Check code

BCC: Block Check Code  
 Refer to the section 4.3 "Check code" for a BCC calculation.

### Delimiter

CR (0Dh): End of packet

- 2) The monitor replies a written in result.

Header	Message	Check code	Delimiter
SOH-'0'-'0'-Monitor ID-'B'-'0'-'A'	STX-'C'-'B'-'0'-'0'-'0'-'1'-ST-ETX	BCC	CR

### Header

SOH (01h): Start of Header  
 '0' (30h): Reserved  
 '0' (30h): Message receiver is the controller.  
 Monitor ID: Indicate a replying Monitor ID.  
 Ex.) When this byte is set to 'A', replying monitor's ID is '1'.  
 'B' (42h): Message type is "Command reply".  
 '0'-'A'(30h, 41h): Message length (10bytes)

### Message

STX (02h): Start of Message  
 'C'-'B'-'0'-'4' (43h, 42h, 30h, 34h): Input name Command  
 '0'-'1' (30h, 31h): Write  
 ST: Status  
 00h (30h, 30h): No Error  
 01h (30h, 31h): Error

ETX (03h): End of Message

Check code

BCC: Block Check Code

Refer to the section 4.3 "Check code" for a BCC calculation.

Delimiter

CR (0Dh): End of packet

### 15.3 Input Name Reset

This command is used in order to reset the Input Name.

- 1) The controller requests the monitor to reset Input Name.

Header	Message	Check code	Delimiter
SOH-'0'-Monitor ID-'0'-'A'-'0'-'8'	STX-'C'-'A'-'0'-'4'-'0'-'2'-ETX	BCC	CR

#### Header

SOH (01h): Start of Header  
 '0' (30h): Reserved  
 Monitor ID: Specify the Monitor ID of which you want to change a setting.  
 Ex.) If Monitor ID is '1', specify 'A'.  
 '0' (30h): Message sender is the controller.  
 'A' (41h): Message type is "Command".  
 '0'-'8'(30h, 38h): Message length (8bytes)

#### Message

STX (02h): Start of Message  
 'C'-'A'-'0'-'4' (43h, 41h, 30h, 34h): Input Name Command  
 '0'-'2' (30h, 32h): Reset  
 ETX (03h): End of Message

#### Check code

BCC: Block Check Code  
 Refer to the section 4.3 "Check code" for a BCC calculation.

#### Delimiter

CR (0Dh): End of packet

- 2) The monitor replies result.

Header	Message	Check code	Delimiter
SOH-'0'-'0'-Monitor ID-'B'-'0'-'A'	STX-'C'-'B'-'0'-'0'-'0'-'2'-ST-ETX	BCC	CR

#### Header

SOH (01h): Start of Header  
 '0' (30h): Reserved  
 '0' (30h): Message receiver is the controller.  
 Monitor ID: Indicate a replying Monitor ID.  
 Ex.) When this byte is set to 'A', replying monitor's ID is '1'.  
 'B' (42h): Message type is "Command reply".  
 '0'-'A'(30h, 41h): Message length (10bytes)

#### Message

STX (02h): Start of Message  
 'C'-'B'-'0'-'4' (43h, 42h, 30h, 34h): Input name Command  
 '0'-'2' (30h, 32h): Reset  
 ST: Status  
 00h (30h, 30h): No Error  
 01h (30h, 31h): Error  
 ETX (03h): End of Message

#### Check code

BCC: Block Check Code  
 Refer to the section 4.3 "Check code" for a BCC calculation.

#### Delimiter

CR (0Dh): End of packet

All data are subject to change without notice.

(October 15, 2018)

**Copyright 2004-2018 NEC Display Solutions, Ltd. All Right Reserved**

This document provides the technical information for users. NEC Display Solutions, Ltd. reserves the right to change or modify the information contained herein without notice. NEC Display Solutions, Ltd. makes no warranty for the use of its products and bears no responsibility for any errors or omissions which may appear in this document.