

eBeam Education Suite

Version 2.4



© Luidia Incorporated, 2011

Table of Contents

About...	4
What's New	5
Minimum System Requirements	6
Setup	7
Hardware Setup	7
eBeam Edge(TM) Setup	8
eBeam Classic Setup	11
The Interactive Stylus	13
Software Setup	15
eBeam Education Taskbar Menu	18
Bluetooth Wireless Setup	19
eBeam Edge Setup	20
eBeam Classic Setup	21
Bluetooth Wireless Settings	23
Interactive Hardware Detection	24
Calibration	25
eBeam Education Options & Preferences	26
eBeam Education Options	26
Scrapbook Options	28
eBeam System Preferences	28
eBeam Tool Palette	30
Handwriting Recognition Tool	34
On-Screen Keyboard	35
Recorder	36
Snapshot	39
Text Tool	40
Voting Tool	41
Standard Annotation Toolbar	43
eBeam Home	44
eBeam Home Shortcuts	45
eBeam Scrapbook	47
Scrapbook Menus	47
File Menu	48
Edit Menu	51
View Menu	54
Cover Sheet	56
Master Page	57
Layers	58
Playback	60
Spotlight	61
Page Menu	62
Meetings Menu	64
Help Menu	65
Scrapbook Features	66
Scrapbook Elements	66
Scrapbook Elements Edit Toolbar	71
Background Settings	74
Hyperlinked Elements	76
Importing PowerPoint, Excel and Word Documents	78
Exporting Documents into Scrapbook	80

Gesture Based Navigation	81
eBeam Inscribe Wireless Tablet	84
Document Camera	87
Gallery	89
Adding Images to Scrapbook Pages	89
Favorites	90
Templates	92
Flickr	94
Encyclopædia Britannica	95
Shared Meetings	97
What is a Shared Meeting?	97
Hosting/Sharing a Meeting	98
Join a Meeting	100
Sending an Invitation	101
Accepting an Email Invitation	102
Archive a Meeting	103
Retrieve a Meeting	105
Participants	109
Chat	111

About...

eBeam Education Suite

Version 2.4

eBeam Education Suite is made up of eBeam Scrapbook, the eBeam Tool Palette and eBeam Home. eBeam Education Suite makes it easy to develop, organize and communicate classroom information. It includes software applications that allow you to annotate lessons on-the-fly, create and save multi-page brainstorm sessions and mark up content from outside applications. eBeam Education Suite software is easy to set up and intuitive to use, creating a fun learning environment for students and teachers, and enhancing the impact of every lesson plan.

eBeam Scrapbook is a powerful resource that can be used to create lessons, store annotations and enliven curriculum material.

The eBeam Tool Palette provides quick access to important tools that can be used as a part of Scrapbook, in conjunction with your every day applications or to annotate over your entire desktop. The tools in the eBeam Tool Palette change depending on the environment that you are working in.

eBeam Home works on top of Scrapbook. It creates a centralized shortcut to the most commonly used resources, making the eBeam Education Suite an even more integral part of everyday teaching resources.

Copyright © 2011 Luidia, Inc.
All rights reserved.

The publications included with the interactive product are protected by copyright, and all rights are reserved. No part of it may be reproduced or transmitted in any form or by any means for any purpose without express prior written consent from Luidia, except as expressly permitted herein. Information in this document is subject to change without notice and does not represent a commitment on the part of Luidia.

The software described in this publication is furnished under license and may only be used or copied in accordance with the terms of such license.

Portions of the Scrapbook Gallery ©2011 Luidia, Inc. All Rights Reserved.

Portions of the Scrapbook Gallery ©2005 Mythic Wave Productions, Inc. All Rights Reserved.

Rev 2.4

What's New

New Features with this release:

- For files saved before version 2.3.3, converted text retains its type size and location.
- Correction: In Scrapbook, changes in Annotation or Snapshot mode are saved even when Scrapbook isn't open.
- In Powerpoint, the tool palette remains visible when you select the next slide.

Minimum System Requirements

- Windows-compatible computer with Pentium IV or equivalent with 1GB RAM
- Windows 7, Vista or XP
- 120 MB available hard drive space for standard eBeam Education Suite software
- 65K color SVGA or comparable high performance video card
- CD-ROM drive or Internet connection (for software installation)
- Internet connection (for registering your software and participating in shared meetings)
- One available USB port or Bluetooth connection
- Digital projector or display device attached to computer

Setup

Hardware Setup

Select a topic below for a description of how to set up an eBeam system. If your system is not described here then refer to the setup documentation included in the box.



[eBeam Classic Setup](#)



[eBeam Edge\(TM\) Setup](#)

[eBeam Engage\(TM\) Setup](#)

eBeam Edge(TM) Setup

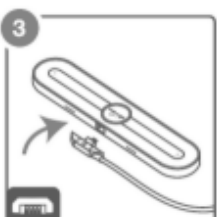
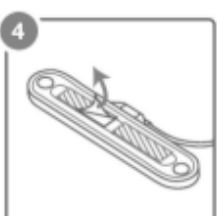
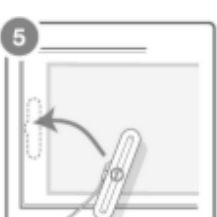
This section demonstrates the quick setup instructions for the eBeam(R) edge(TM) receiver.

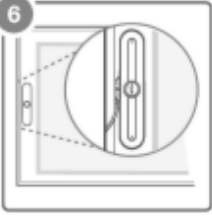
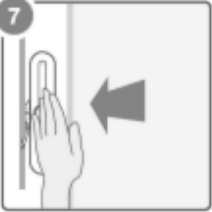
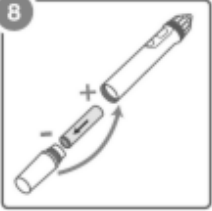

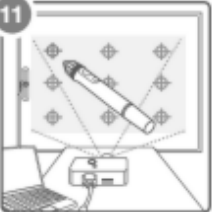
 <p>1</p>	<p>Connect your projector to your computer.</p>
 <p>2</p>	<p>Turn on your projector and align/focus the image on the board.</p>
 <p>3</p>	<p>Connect the eBeam USB cable to your eBeam Receiver.</p>
 <p>4</p>	<p>Peel the Command Adhesive backing from the Receiver.</p>
 <p>5</p>	<p>Hold the Receiver and prepare to place it carefully in the indicated location.</p>
	<p>Place the Receiver so that it is centered vertically on the board and parallel to the frame.</p>

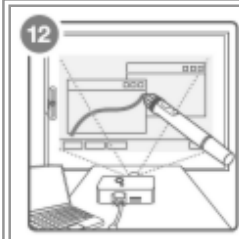

	
	<p>Press the Receiver firmly against the board for best adhesion.</p>
	<p>Install the AAA battery in your eBeam Stylus.</p>
	<p>Connect the eBeam USB cable to your computer USB port.</p>
	<p>Insert the eBeam software CD and install.</p>
	<p>Launch the eBeam software and calibrate the system.</p>
	<p>Finished!</p>

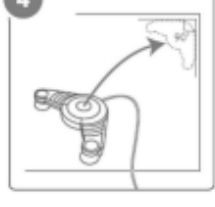
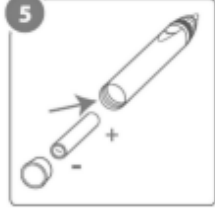

eBeam Classic Setup

The following describes a typical setup for the eBeam USB or Bluetooth Wireless receivers and related hardware.

	<p>Connect your projector to your computer.</p>
	<p>Turn on your projector and align/focus the image on the board.</p>
	<p>Connect the eBeam USB cable to your eBeam Receiver.</p>
	<p>Attach the eBeam Receiver mounting bracket to the board.</p> <p>The eBeam package contains the following receiver mounting options.</p> <ul style="list-style-type: none">• Suction cups• Command adhesive• Magnetic mounting brackets <p>The eBeam Receiver is pre-attached to the suction cup mounting bracket. To detach any of the mounting brackets from the eBeam Receiver, position thumbs at bottom corners of the bracket and push up; the bracket should easily snap off.</p> <p>To secure brackets to the receiver, position the desired bracket over the back of the receiver and snap it into place. To permanently fasten the receiver, use the clear mounting bracket -- the one without suction cups. Fasten the receiver to the mounting surface through the holes in the clear mounting bracket.</p>
	<p>Install the AA battery in your eBeam Stylus.</p>

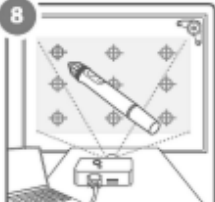
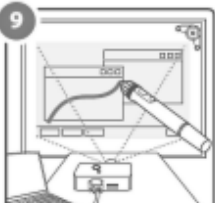
	<p>6</p> <p>Connect the eBeam USB cable to your computer USB port.</p>
	<p>7</p> <p>Insert the eBeam software CD and install.</p> <p>For additional information on setting up Bluetooth on your computer, see Bluetooth Wireless Configuration.</p>
	<p>8</p> <p>Launch the eBeam software and calibrate the system.</p>
	<p>9</p> <p>Finished!</p>

The Interactive Stylus

The Interactive Stylus was created specifically for use with an eBeam-enabled projection system. The Interactive Stylus behaves exactly like a mouse attached to your computer.

Model 303

Model 305



In this document, we often refer to a tap on the board as opposed to a mouse click to indicate that you are using the Interactive Stylus to perform an action.

See [Gesture Based Navigation](#) for a description of advanced software navigation using the Interactive Stylus.

The following table shows the different components of the Interactive Stylus and what those components do.

Name	Model 303	Model 305	Description
Menu Button			The Menu Button is the equivalent of the right-click button on your mouse.
Tool Palette Button			The Tool Palette Button shows and hides the eBeam Tool Palette. This button is also used for Gesture Based Navigation .
Pen Tip			The Pen Tip performs the same action as the left-click button on your mouse.

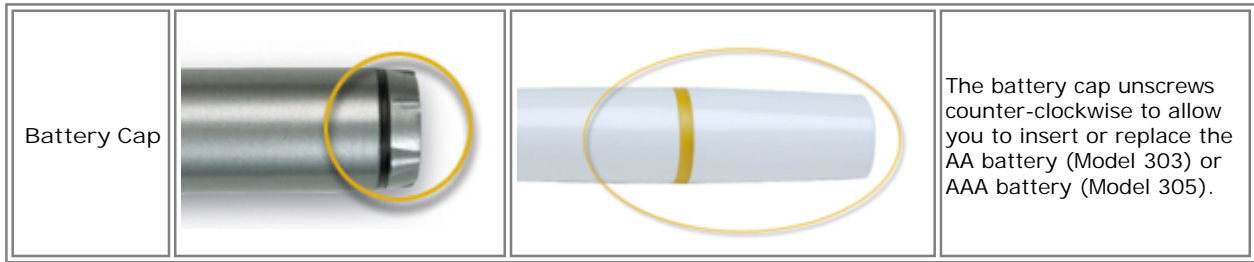

Software Setup

The interactive software can be installed from the installation CD that came in the box or from a downloaded web package.

At launch, the software provides access to the basic software feature set. The options for unlocking the full software feature set are:

- Connect the software to an interactive receiver.
- Activate the software using a CD-Key or security key (see The Welcome Dialog Box).
- Use your [eBeam Focus Document Camera](#) as a security key.
- Use your [eBeam Inscribe Wireless Tablet](#) as a security key.

If the software does not detect the interactive hardware or a security key at launch, then you will be prompted with the Welcome dialog box to complete your software setup.

The Welcome Dialog Box

The Welcome dialog box appears when you are not connected to the interactive hardware and have not installed a software activation code.

To launch the software select one of the following options:

- [Connect](#): I have an interactive receiver and I need help connecting it.
- Activate: I want to use a software license key to activate the software.
- Try: I want to use the full feature set of the software for 30 days.
- Join a meeting: I just want to join a meeting as a remote participant.
- To use the software to simply open and edit Scrapbook files, click the Close button.

Activate the Software Using a Software License Key

A Software License Key is included with some products or can be acquired from your product vendor. One software license key is required to activate a single Windows PC.

To activate your software:

1. Make sure your computer is connected to the Internet.
2. Launch the software.
3. Go to the activation website by one of the following methods:
 - Select the Activate Now button from the Welcome dialog box, or
 - Select Options from the [eBeam Education taskbar menu](#), choose the Activation tab and then select Get Activation Code.

This opens your default web browser to Luidia's website where you are prompted to enter the software license key and your contact information.

4. Enter your software license key and contact information in the activation web page.

Once all information has been properly entered, the website will email an activation code to the email address that you have just provided.

5. Copy the activation code from the email into the text field in the Activation tab.
6. Click the Activate Now button.

The software will activate and launch. You will not need to enter the activation code again.

Notes:

- If a valid activation code or security key is detected you might still be prompted to connect to the interactive hardware. This prompt exists to assist users who use the software with a hardware connection. If you do not wish to be prompted again then you can uncheck the Display this notification when interactive hardware not found checkbox from the dialog box or by navigating to the System Preferences > System tab.
- Existing users may activate the software using a security key (HASP dongle). This option is only available to existing users who already possess a security key. Simply plug the security key into your USB port prior to launching the software.
- See also: [Deactivating or Moving the Software to Another Computer](#).

Try the Software for 30 Days

Select the Try option to enable the full feature set of the software for 30 days.

Use the Software as a Viewer (basic features only)

Each time you launch the software, the software first attempts to locate interactive receiver hardware, a valid activation code or a security key (HASP dongle). If these items are not detected then only the basic software features are available and the eBeam Education taskbar icon is disabled.

If you only wish to use the software to join a shared meeting, select the Join Meeting button from the Welcome dialog box.

If you only wish to use the software to open a Scrapbook file, select the Close button from the Welcome dialog box. Scrapbook will open automatically.

Deactivating or Moving the Software to Another Computer

If you want to move the software to another computer, you will first need to deactivate it on your current computer. To deactivate the software:

1. Open the Activation tab by selecting Options from the [eBeam Education taskbar menu](#) , then click on the Activation tab.
2. Select the Deactivate Now button.
 - Remember that if you deactivate the software you will only have access to the basic software features.
3. Copy the reference number provided and send to technical support at <http://www.e-beam.com/support/techform.html>. Technical support will make sure that you can then activate the software on another PC.

Note: Technical support might require 24 hours to reset your activation.

eBeam Education Taskbar Menu

The following menu items are offered from the eBeam Education taskbar menu:

Menu Item	Description
Interactive Tools	Shows/hides the eBeam Tool Palette.
Scrapbook	Opens Scrapbook .
Spotlight	Opens Spotlight.
Calibrate Interactive Area	Initiates the calibration. The interactive hardware must be detected by the software before calibration can begin.[\$X\$IF_CON3] Not active in this software version.[\$X\$END_CON3]
Detect System	Attempts to detect the interactive hardware. See Interactive Hardware Detection .[\$X\$IF_CON3] Not active in this software version.[\$X\$END_CON3]
Options	Opens the Options dialog box. See Options .
About	Displays the About dialog box for the software. To close, click anywhere in the About dialog box.
Help	Opens a sub-menu that allows you to access help and also provides links to various registration and support pages that are provided by the hardware manufacturer of your interactive system.
Exit	Completely closes the software. If you have Scrapbook open, you will be prompted to first save the Scrapbook file.

Bluetooth Wireless Setup

Select a topic below for a description of how to configure your Bluetooth connection for your eBeam Bluetooth Wireless system. If your system is not described here then refer to the setup documentation included in the box.

[eBeam Edge\(TM\) Setup](#)

[eBeam Classic Setup](#)

[Bluetooth Wireless Settings](#)

eBeam Edge(TM) Setup

For your eBeam Edge Bluetooth receiver to work properly, you must have Windows XP SP2 or later, Vista, or 7.

Set up a Bluetooth Wireless connection to the receiver

1. Plug the Bluetooth USB key that came with your eBeam Edge product into a USB port on your PC. Two events should occur:
 - The Windows New Hardware Setup message should appear in your taskbar telling you that the device has been detected.
 - A Bluetooth icon should appear in your taskbar.
2. Right click the Bluetooth icon in your taskbar and select Add A Bluetooth Device.
3. Complete the Add Bluetooth Device Wizard.
 - a) Make sure My device is set up and ready to be found is checked. Click Next.
The Windows operating system will search for Bluetooth devices.
 - b) Select your eBeam device from the list. Click Next.
 - c) Select Use the passkey found in the documentation and type in 1234. Click Next.
The Windows operating system will now install the eBeam Bluetooth receiver.
 - d) Click Finish.
4. Launch the software. The software will automatically detect the Bluetooth receiver.

eBeam Classic Setup

eBeam Classic Bluetooth Setup

The Bluetooth-enabled eBeam Classic is supported only on Windows Vista, Windows 7 or Windows XP Service Pack 2 or higher at this time.

To check the Service Pack level you are working with go to Start > Control Panel > System. Before you begin, make sure you have the latest eBeam software as well as an updated IOGEAR driver installed on your computer. Visit <http://www.iogear.com/support/dm/> to get the updated driver and setup instructions for your computer.

Select the computer that you are working with to finish your setup:

- [Windows 7 / Vista Setup](#)
- [Windows XP Setup](#)

Windows 7 / Vista Setup

- 1) Plug your eBeam receiver into a power outlet, and confirm that the light is glowing blue.
- 2) If your IOGEAR isn't already inserted into an available USB port on your computer, do so at this time.
- 3) Verify that your computer has recognized the inserted Bluetooth adapter. Look for a Bluetooth icon in the system tray of your computer (in the lower right-hand of the screen).
- 4) Right-click on the Bluetooth icon and select "Add A Device" / "Add a Bluetooth Device". Your Bluetooth Wizard will begin.
- 5) Highlight your Bluetooth-enabled eBeam device and click Next. (Your device will be called eBeam-"XXXXXX").
- 6) Select "Use the passkey found in the documentation" / "Enter the device's pairing code".
- 7) Enter "1234", and click Next. (This passkey will be requested whenever you pair the eBeam receiver with another computer.)
- 8) Finish the Bluetooth Wizard, and verify that the glowing blue light on your eBeam receiver flashes four times. Your setup is complete.

Windows XP Setup

- 1) Plug your eBeam receiver into a power outlet, and confirm that the light is glowing blue.
- 2) Insert the IOGEAR adapter into an available USB port on your computer.
- 3) Verify that your computer has recognized the inserted Bluetooth dongle. Look for a Bluetooth icon in the system tray of your computer (in the lower right-hand of the screen).

- 4) Double click the Bluetooth icon and your Bluetooth Wizard will begin. Leave all 3 boxes checked and click Next.
- 5) A General dialog box appears allow you to change the name of your computer and select your computer type. Click Next twice.
- 6) The Bluetooth Service Selection Dialog Box allows you to choose what services you would like your computer to offer other computers. Uncheck all of the boxes and click Next twice.
- 7) Make sure the drop down menu is set to "Show All Devices". Select your eBeam receiver and click Next. (Your device will be called eBeam-"XXXXXX").
- 8) Enter "1234", and click Next. (This passkey will be requested whenever you pair the eBeam receiver with another computer.)
- 9) Check the box next to "White Board" and select Configure.
- 10) Uncheck "Secure Connection" and click OK.
- 11) Finish the Bluetooth Wizard, and verify that the glowing blue light on your eBeam receiver flashes four times. Your setup is complete.

Bluetooth Wireless Settings

The Bluetooth Settings Dialog Box can help you set preferences for your Bluetooth-enabled eBeam receiver. To open this dialog box your Bluetooth receiver must be connected to your computer with a USB cable and your software must be launched. To open the dialog box:

- Right-click the eBeam Education icon in the [eBeam Education Taskbar menu](#)
- Select Options
- On the General Tab select System Preferences
- On the System Tab select Bluetooth Settings. The Bluetooth Settings Dialog Box will open.

Bluetooth Settings Dialog Box

The Bluetooth Settings Dialog Box contains the following options:

Friendly Name	Shows the name for the Bluetooth receiver that is listed on the PC when you search for Bluetooth devices. The eBeam receiver is shipped with a default Friendly Name. Change: Select this button to change the Friendly Name. You will need to enter a new Friendly name into the Change Friendly Name Dialog Box, and click OK. There is an eight character limit on the Friendly Name. You must select the Apply New Settings button to accept any changes.
Security	Allows you to determine who can use the Bluetooth enabled receiver. You must select the Apply New Settings button to accept any changes. The options include: <ul style="list-style-type: none"> • Allow the eBeam receiver to be "discovered" by Bluetooth enabled devices : Lets you set if the Bluetooth Wireless receiver can be detected by Bluetooth enabled devices. If this box is not checked, other Bluetooth enabled devices will not be able to detect it without knowing the Friendly Name. • Require Authentication: Allows you limit access to the Bluetooth Wireless receiver to only those people who have receiver's PIN number. • Passkey: Select the Change button to change the passkey for your receiver. • Use Encryption: Ensures that wireless transmissions are secure from unauthorized access.

Interactive Hardware Detection

Every time you launch the software or select Detect System from the [eBeam Education taskbar menu](#), the software attempts to connect your interactive hardware. If the interactive receiver hardware is not detected, you are prompted to connect to the hardware.

Detect Interactive Receiver Dialog Box

The following options are available from the Detect Interactive Receiver dialog box:

Help	Launches eBeam Education Suite Help.
Setup	Opens the eBeam System Preferences dialog box where you can change hardware detection frequency and notifications.
Cancel	Closes the Detect Interactive Receiver dialog box and allows your to use the limited eBeam Education Suite software without a receiver.
Retry	Starts a new search for your interactive receiver. Choose this if you believe your hardware is connected, but was not detected.

Disabling the Hardware Detection Prompt

Every time the software attempts to connect to the hardware you will be prompted to connect to the interactive hardware. If a valid activation code or security key is detected you might still be prompted to connect to the interactive hardware. This prompt exists to assist users who use the software with both a software activation and hardware connection.

You can turn this notification on/off by navigating to the System Preferences > System tab and selecting the Display this notification when interactive hardware not found checkbox.

Calibration

Calibrating Your Software

You need to calibrate your surface so that the eBeam Education Suite software knows what size whiteboard or flat surface you are using.

To calibrate your surface, you will need to make sure your interactive receiver is setup and detected and that the software is launched.

To initiate a calibration,

- Select the Calibrate  button from the Tool Palette if Scrapbook is not open, or
- Select Calibrate Interactive Area from the [eBeam Education taskbar menu](#) at any time.

You will calibrate by clicking the Interactive Stylus on the targets in the projected area as directed by the software. If you have multiple monitors you will see the message [Click here to calibrate this screen](#) (press ESC to cancel calibration). Select the desired projected area and calibrate.

eBeam Education Options & Preferences

eBeam Education Options

The eBeam Education Options dialog box is used to set the eBeam Tool Palette and drawing specific preferences. The eBeam Education Options Dialog Box can be opened by selecting eBeam Education Taskbar Menu > Options . There are three tabs available here:

- [General Tab](#)
- [Annotations Tab](#)
- [Activation Tab](#)

General Tab

Palette Options	<ul style="list-style-type: none"> • Size: This option allows you to resize the Tool Palette. • Transparency: This option allows you to select the transparency of the Tool Palette.
Features	<ul style="list-style-type: none"> • Hide Cursor When Drawing: Hides the Windows' arrow during annotations. You can also access this option by selecting Edit > Options > Preferences tab in Scrapbook. • Double-Click Eraser Clears Screen: Allows you to double-click the Eraser tool to erase all annotations created while annotating your desktop or during a PowerPoint Presentation. • Sticky Palettes: If a tool has a secondary palette, such as a color ring or line thickness ring, that secondary palette will be opened automatically each time the tool is chosen. The last used secondary palette will be remembered and opened by default the next time the tool is selected. • Gesture Based Navigation: Turns on/off gesture based navigation. • Smooth Drawing: Smooths lines drawn by the eBeam Stylus. You can also access this option by selecting Edit > Options > Preferences tab in Scrapbook.
Restore Defaults	The Restore Defaults button causes all Tool Palette Options to be returned to their default settings.
Restore Default Colors	If any custom colors have been selected, Restore Default Colors resets all colors to the default color set.
System Preferences	Opens the eBeam System Preferences dialog box. See eBeam System Preferences for more information.

Annotations Tab

The Annotations tab allows you to set behavior for how desktop and PowerPoint annotations are saved. The following options are available:

After Annotating the Desktop	<p>When you finish annotating your desktop, you can keep a record of the annotated desktop as a new page in Scrapbook. Options for desktop annotations are Save, Discard, or Ask Each Time.</p> <ul style="list-style-type: none"> • Always save as new Scrapbook page: The annotated page becomes a new page in Scrapbook. Save the Scrapbook file to keep the new Scrapbook page. • Always discard annotations: The annotated page is automatically discarded. No record is kept. • Ask me each time: When you finish annotating the desktop, you will be prompted to save the annotated page as a new page in Scrapbook. You will have the choice to save or discard the page.
------------------------------	--

	<ul style="list-style-type: none"> • Open Scrapbook after saving annotations: Default setting – opens Scrapbook. This setting gives you immediate feedback that your annotation has been placed in Scrapbook. Save the Scrapbook file to keep the new Scrapbook page.
<p>Navigating an Annotated PowerPoint Slideshow</p>	<p>When you change slides in a PowerPoint Slideshow, you must choose whether or not to save annotations into the PowerPoint file as objects. Options for desktop annotation are Save, Discard, or Ask Each Time.</p> <ul style="list-style-type: none"> • Always add objects to PowerPoint file: The annotations are automatically saved to each slide as an object on the slide. You must save the PowerPoint file to keep the annotations permanently. • Always discard annotations: The annotations are automatically discarded. No record is kept. • Ask me each time: Each time you change slides, you will be prompted to save the annotations as objects. You must save the PowerPoint file to keep the annotations permanently.

Activation Tab

The following options are available in the Activation Tab:

Purchase License Button	Launches the Luidia store where you can purchase a license key to activate the eBeam software.
Get Activation Code Button	Launches the Luidia Software Activation Request form so you can request an activation code. You will need to request an activation code if you deactivate your software or move your software to another computer.
Activation Code Text Box	Once you receive an activation code, paste it in the Activation Code Text Box and press Activate Now.
Activate Now Button	Once a code is entered into the activation code text box, pressing Activate now starts the activation of your eBeam software.

Scrapbook Options

eBeam System Preferences

The System Preferences dialog in the Windows Control Panel allows you to set hardware specific preferences.

If your receiver is not detected, see [Interactive Hardware Detection](#).

There are two tabs that can be accessed in System Preferences.

- The [System Preferences](#) tab.
- The [Projection](#) tab.

System Preferences Tab

Communication Port	<ul style="list-style-type: none"> • Autodetect: If Autodetect is selected, the software will automatically attempt to connect to interactive hardware on USB and COM communication ports. • Connect To: The Connect To option allows you to manually specify which communication port to connect to the hardware on. • Detect Device: Attempts to detect the interactive hardware. • Close Connection: Software disconnects from the hardware. Frees the port. • Bluetooth Settings: Opens the Bluetooth Wireless System Configuration Settings dialog. See Bluetooth Wireless Configuration for more information. The receiver must be connected to the PC with a USB cable in order to be configured. • Connect To LAN: If your OEM interactive Receiver provides an option for connection to a Local Area Network, see your OEM hardware or software manual for instructions.
Advanced	<ul style="list-style-type: none"> • Open appropriate application when stylus or marker pen is used. If this is checked: <ul style="list-style-type: none"> ○ When a Marker Pen is used, the whiteboard software opens (if installed). ○ When an Interactive Stylus is used, the projection software opens. • Display Low Battery message: If this is checked, a low battery warning will appear when the pen or eraser battery is low. • Display system connecting status: If this is checked, a status dialog box will appear while the software attempts to connect to the hardware. • Hardware Diagnostics: Displays information used by technical support to diagnose environmental problems. The receiver must be connected to the PC either wirelessly or with a USB cable and must be detected by the software. • System Information: Opens the Windows System Information dialog box.

Projection Tab

Calibration	<ul style="list-style-type: none"> • The Calibration section allows you to launch the projection calibration process by selecting Calibrate Projection Area button.
-------------	--

Stylus Buttons

- The Stylus Buttons section allows you to configure each of the two buttons on the Interactive Stylus.

For each button, it is possible to set the button to be:

- Off - Button causes no action
- Left Click - Left mouse click
- Middle Click - Middle mouse click
- Right Click - Right mouse click
- Move Cursor - Causes the mouse cursor to hover
- Show/Hide Tool Palette - Open close the eBeam Tool Palette.

Select button options from the pull down lists.

eBeam Tool Palette

The eBeam Tool Palette is used to navigate, annotate and edit the content on your computer. The tools on the Tool Palette change depending on the application that you are using. The four main places that you can use the Tool Palette are: in PowerPoint, in Scrapbook, on top of all applications (in Screen Annotation Mode) or outside of any application.







Note: Whenever a Tool has the  arrow symbol, that indicates that there is another tool available as in the submenu of this tool. Click and hold the arrow, and the sub menu will appear. While holding, select the tool you would like to use and release.















To show or hide the Tool Palette:











- Press the Tool Palette button on the [Interactive Stylus](#), or
- Select eBeam Tool Palette from the [eBeam Education taskbar menu](#) .

The eBeam Tool Palette appears automatically whenever a receiver or security key is detected and you launch eBeam Home or eBeam Scrapbook. If no receiver or security key is detected and you launch these applications, the Standard Annotation Toolbar launches instead of the eBeam Tool Palette.

The following tools are available on the eBeam Tool Palette, depending on the application you are using:

Calibrate Tool		The Calibrate Tool starts the interactive calibration process. See Calibration for more information.
Eraser Tool		The Eraser Tool allows you to erase annotations made using the pen or highlighter tool. The Eraser Tool cannot erase objects made using the shapes tool.
Exit PowerPoint Presentation Tool		The Exit PowerPoint Presentation Tool causes the PowerPoint slide show to be ended. This tool is not available once you are outside of a PowerPoint presentation.
Handwriting Recognition Tool		The Handwriting Recognition Tool turns the Handwriting Recognition software on/off. The Handwriting Recognition Tool is located in the submenu of the Text Tool. See Handwriting Recognition for more information.
Highlighter Tool		The Highlighter Tool allows you to annotate the desktop freehand. When the Highlighter Tool is selected, the center of the Tool Palette changes to show the current color and line width settings. A custom color can be selected by double-clicking a color on the palette ring. The standard set of colors can be restored by selecting eBeam Education Options > General Tab > Restore Defaults. Note: Some highlighter colors may not be visible on some computer backgrounds.
Mouse Tool		The Mouse Tool allows you to start navigating your desktop.

New Page Tool		The New Page Tool creates a new page in a Scrapbook file. The new page is inserted directly after the display page. The New Page Tool is available in the sub menu of the Snapshot Tool.
On-Screen Keyboard Tool		The On-Screen Keyboard Tool allows you to enter text by tapping keys with the Interactive Stylus. You can close the On-Screen Keyboard by selecting the On-Screen Keyboard button again or selecting the red close (X) button on the On-Screen Keyboard. See On-Screen Keyboard for more information.
Options Tool		The Options Tool launches the eBeam Education Options dialog box.
Pen Tool		The Pen Tool allows you to annotate the desktop freehand. When the Pen Tool is selected, the center of the Tool Palette changes to show the current color and line width settings. A custom color can be selected by double-clicking a color on the palette ring. The standard set of colors can be restored by selecting eBeam Education Options > General Tab > Restore Defaults.
Pointer Tool		<p>The Pointer Tool is enabled only during a shared meeting. It allows each participant to point to data within the meeting window. Each participant's pointer is displayed in a different color. When the Pointer Tool is selected, the outside ring of the Tool Palette changes to show the different pointer settings. The following options are available:</p> <ul style="list-style-type: none">  Rotate pointer counter-clockwise: Rotates the pointer 90 degrees in a counter-clockwise direction.  Show Pointer: Shows the pointer on the screen.  Rotate pointer clockwise: Rotates the pointer 90 degrees in a clockwise direction.  Hide Pointer: Hides the pointer. <p>The Pointer Tool is available in the sub menu of the Select Tool.</p>
PowerPoint Mouse Tool		The PowerPoint Mouse Tool allows you to navigate a PowerPoint slide show
Recorder Tool		The Record Tool allows you to record everything that happens on your desktop including voice tracks from your computer's microphone. The Recorder Tool is available in the sub menu of either the Save Tool, the Snapshot Tool, or the Exit PowerPoint Presentation Tool depending on what environment you are in. See Recorder for more information.
Redo Tool		The Redo Tool allows you to redo the last undone annotation. You can redo multiple times back to the beginning of a series of changes. Redo is disabled once a new annotation occurs.
Save Tool		The Save Tool allows you to save a snapshot of your desktop into Scrapbook as a new page. As the new page is being saved, a save icon will appear on your desktop. You must save the Scrapbook file if you want to keep the page permanently.
Scrapbook Tool		The Scrapbook Tool opens/hides the Scrapbook application.
Screen Annotation		The Screen Annotation Tool changes you to Screen Annotation Mode. When you enter Screen Annotation Mode, a snapshot is taken of your desktop. This snapshot is turned into the background image that you can write on while you are in Screen Annotation Mode. A translucent frame appears around the border of your screen indicating that you are in this mode.

not atio n Too l		
Select Too l		The Select Tool allows you to select a single Scrapbook element to move, rotate, resize, group or copy. You can also draw a bounding rectangle around a group of elements with the select tool. For more information about working with Scrapbook elements, see Scrapbook Elements.
Sh ape s Too l		The Shapes Tool allows you draw shapes. When the Shapes Tool is selected, the center of the Tool Palette changes to show the current color, shape and line width settings.
Slid e Bac k Too l		The Slide Back Tool allows you to move to the previous page in a Scrapbook file or Powerpoint presentation.
Slid e For war d Too l		The Slide Forward Tool allows you to move to the next page in a Scrapbook file or PowerPoint presentation.
Sn aps hot Too l		The Snapshot Tool allows you to take a picture of the current screen and save it into Scrapbook as either a background image in a new page or Scrapbook element in the current page. See Snapshot for more information
Sp otli ght Too l		The Spotlight Tool highlights a particular region of your desktop. See Spotlight for more information.
Sta rt Po wer Poi nt Pre sen tati on Too l		The Start PowerPoint Presentation Tool opens the Open File dialog box so you can browse your files and select a PowerPoint presentation to open.
Tex t Too l		The Text Tool allows you to add a text box to the displayed page. See Text Tool for more information.
Un do Too l		Undo erases the previous annotation.
Vot ing Too l		The Voting Tool opens the Voting response system. The Voting Tool is available in the sub menu of the PowerPoint Mouse Tool. See Voting Tool for more information.
Zoo m Too l		The Zoom Tool allows you to zoom into or out of the page displayed in Scrapbook. When the Zoom Tool is selected, the center of the Tool Palette changes to show the current zoom settings. You can either choose a percentage to zoom in to, or select: <ul style="list-style-type: none"> Zoom in (+): Zooms the page in by a factor of 1.25 to no greater than 2000%

		<ul style="list-style-type: none">• Fit Page (): Compresses or expands the page to fit into the page display area. Fit Page can also be selected by pressing Ctrl+0.• Zoom out (-): Zooms the page out by a factor of 1.25 to no lower than 25%
--	--	---

Handwriting Recognition Tool

Handwriting Recognition is used to convert [Interactive Stylus](#) annotations into text that can be used in Text Boxes and dialog boxes.

eBeam Education Suite software specifically works with ritePen® version 2.5 or later or MyScript® Stylus version 2.6 or later.

To update to the latest version, visit www.visionobjects.com for MyScript and www.evernote.com for ritePen.

On-Screen Keyboard

On-Screen Keyboard opens a floating On-Screen Keyboard that you can use to enter text. You can change the font and font size of the text by using the Text Edit Toolbar. You can close the On-Screen Keyboard by selecting the On-Screen Keyboard button again or selecting the red close (X) button.

Keyboard Options

To open the On-Screen Keyboard Options, select the Option key from the keyboard. The following options are available:

Use Click Sound	Turns on a clicking sound when you tap each key
Turn on Numeric Key Pad	Adds the numeric key pad to the right of the keyboard
To Use the On-Screen Keyboard	<ul style="list-style-type: none"> • Click on Keys: Allows you to select keys by clicking them. • Hover over Keys: Allows you to select keys by hovering over them. You can set the duration of time you need to hover before a key is selected. • Scan through Keys: Allows you to select keys as the keyboard is automatically scanned. You can select which key click you need to select before the scanning will stop.
Text prediction	Allows you to use text prediction to guess the word as you are entering the text. You can also determine whether or not you would like a space after each predicted word.

See Text Tool for information about using the On-Screen Keyboard to create text and for changing text attributes.

Recorder





Use Recorder to record everything that happens on your desktop including voice tracks from your computer's microphone. Play back your recording instantly in our Movie Player if you save the recording in the default *.ebm format. Or save your recording as an .avi, .swf or .wmv movie.

See the following Recorder topics:

- [Recorder Controls](#)
- [Recorder Options](#)
- [Movie File Type Options](#)

Recorder Controls

The Recorder menu contains:

<p>Start Recording</p>		<p>The Start Recording button causes Recorder to immediately begin recording.</p> <p>The Start Recording button has a sub-menu palette that allows you to select the size of your recording area. From left to right, the options are:</p> <ul style="list-style-type: none"> • Record Entire Screen: Recorder captures everything shown in your primary monitor. • Record Selected Area: You will be prompted to drag your mouse to select an area of the primary monitor to record. • Record Window: You will be prompted to drag cross hairs from a dialog box to the application that you wish to record. If you drop the cross hair on the Scrapbook window, only the Scrapbook Page will be recorded. Note: When recording an application window while using multiple monitors, the application can be located on a secondary monitor.
<p>Pause Recording</p>		<p>Pause Recording stops Recorder temporarily. To begin recording again, click the Start Recording button.</p> <p>To end your recording, first click Start Recording and then click Stop Recording.</p>
<p>Stop Recording</p>		<p>Stop Recording stops the Recorder. You will be prompted to save the movie file. Once the movie file has been saved, a notification dialog will appear that:</p> <ul style="list-style-type: none"> • Displays the movie duration • Displays the movie file location • Gives you the option to play back the movie immediately or to close. <p>The movie is saved in *.avi format, and can be played back in Windows Media Player.</p>
<p>Recorder Status</p>		<p>The Recorder Status box displays recording specific data.</p> <ul style="list-style-type: none"> • Recording indicator . When Recorder is recording, the record indicator is red and blinking. • Audio. If audio is enabled, then a speaker is shown. If audio is disabled, the speaker is not shown. See Recorder Options • Movie Timer . The timer displays how long Recorder has been recording.
<p>Recorder Options</p>		<p>Recorder Options opens the Recorder Options dialog box.</p>

Hide Recorder Wheel		The Hide Recorder Wheel button allows you to keep the Recorder menu from being recorded in your video. Select the Hide Recorder Wheel button to hide the menu. To reopen the menu, select the Recorder tool from the eBeam Tool Palette.
---------------------	---	--

Recorder Options

The Recorder Options dialog box allows you to set audio, video and file save settings specific to Recorder.

Section	Description
Video	<ul style="list-style-type: none"> ● Frame Rate: The frame rate determines how many snapshots per second are taken of your screen. A higher frame rate will cause your movie to be smoother during playback. However, a higher frame rate requires more memory on your PC. Setting the Frame Rate to a lower rate can help when your PC performance is slow. <p><u>Recommended Frame Rate for Available Memory</u></p> <ul style="list-style-type: none"> ○ 100 MB Available Memory - Set the Frame Rate to 5 frames/second ○ 250 MB Available Memory - Set the Frame Rate to 10 frames/second ○ 500 MB or More Available Memory - Set the Frame Rate to 15 frames/second <p>You can determine the amount of available memory by opening Windows Task Manager, under the Performance Tab look at the Physical Memory (K) section, and look at the Available Memory. Divide the Available memory by 1000 to get the number of free MB.</p> <p><u>Recommended Frame Rate for Your Processor:</u></p> <ul style="list-style-type: none"> ○ Pentium IV or Similar Performance - Set the Frame Rate to 5 frames/second ○ Performance less than Pentium IV - In many cases a Frame Rate of 3 frames/second will be sufficient for good performance. However, in severe cases it is necessary to set the Frame Rate to 1 frame/second. ● Turn off hardware acceleration while recording : In some cases, the hardware acceleration setting for your monitor can interfere with recording. This checkbox temporarily disables hardware acceleration. Important Note: After enabling this option, when you start and end recording, your monitor will go black for 1-2 seconds. This is expected behavior.
Audio	<ul style="list-style-type: none"> ● Include Audio Track: Check Include Audio Track if you are using a microphone to record audio. The software checks for an attached microphone and will automatically check this checkbox if it finds a microphone. ● Device: Allows you to select the device. ● Source: Allows you to select the audio source. ● Sample Rate: Choose from a spectrum between 11.025 kHz to 96.0 kHz ● Stereo: Check Stereo to record in stereo. ● MP3 Compression: Check MP3 Compression to access a range of quality from Low quality to Very High quality
Saving Files	<ul style="list-style-type: none"> ● Save here by default: Use the Browse button to select the default file save location. ● Alert me before recording if available disk space is less than: The final movie file can potentially get very big depending on how long the recording is. It is important that there is enough space on your PC to save the file once recording is complete. This option causes a warning dialog to appear when you have reached the specified amount of disk space.

Movie File Type Options

You can save movies as .ebm, .avi, .swf or .wmv file types.

.ebm (eBeam default format)	Plays on Windows using Luidia's Movie Player
.avi (Microsoft Audio Video Interleave)	Plays on Mac OS and Windows using Apple QuickTime Player or Microsoft Windows Media Player
.swf (Macromedia Flash Movie)	Plays on Mac OS and Windows using Adobe Flash Player or a Web browser with a Flash plug-in installed
.wmv (Windows Media Video File)	Plays on Mac OS and Windows using Microsoft Windows Media Player or a Web browser with the Windows Media Player plug-in installed

Snapshot

Snapshot allows you to take a picture of the current screen and save it into Scrapbook either as a background image in a new page or a [Scrapbook element](#) in the current page.

1. Select the Snapshot Tool button.
2. Select one of the following options:
 - Capture screen: Captures the entire desktop as a single image. As a default, the captured image is saved as a background into a new page in Scrapbook. To save the image as a [Scrapbook element](#) on the current page, check the Import as Object checkbox.
 - Capture a selection: Minimizes the Scrapbook, and the cursor becomes a cross hairs. To select an area to capture, use the Interactive Stylus to draw a selection rectangle.
3. Select the Go button to save an image into Scrapbook.

Text Tool

The Text Tool allows you to add a text box to the displayed page. A text box is also a [Scrapbook Element](#).

Modify text attributes through the Text Edit Toolbar which displays whenever a text box is open.

The following buttons are available on the Text Edit Toolbar:

- Font selection
- Font size selection
- Increase font size
- Decrease font size
- Font color
- Text box fill color
- Bold text
- Italicize text
- Underline text
- Left justify
- Center text
- Right justify
- Decrease indent
- Increase indent
- Bullet points
- Text box outline color

Voting Tool

Use the Voting Tool on the Tool Palette with the eBeam Respond RF voting system to allow participants to respond to electronic testing, formative assessments, surveys, opinion polls, games and questions posed by the presenter. The data collected from these keypads is immediately transmitted to the presentation, giving the presenter a better understanding of comprehension.

Before using the Voting Tool on the Tool Palette, make sure that the eBeam Respond product is set up completely. Carefully follow the instructions from the eBeam Respond Quick Start Guide instructions that came with your product.







The eBeam Respond voting response system is powered by TurningPoint® 2008 software. For detailed instructions on how to set up eBeam Respond (voting system) enabled PowerPoint files and similar topics, go to your Start menu > Turning Technologies, LLC > TurningPoint 2008 and refer to the user guides provided for Office 2003 and 2007.



See the following topics:

- [Voting Tool Controls](#)
- [How to Run a Voting Session with eBeam Respond](#)

Voting Tool Controls

The Voting Tool controls are described in the following table.









Tool	Control	Description
Voting Response Window		<p>The Voting Response window contains 2 pieces of information: Number of responses and feedback.</p> <ul style="list-style-type: none"> • Number of responses (shown as 5) shows the number of responses you have received to the current question. If this number is shown in green, voting is still open for this question. If this number is shown in red (see image to left), then voting is closed. • Feedback shows the number of your audience members who pressed the ? on their response card to indicate that they have feedback about the current question.
Repoll Question		<p>Select Repoll Question to clear the previous responses and get ready to accept new responses from the audience for the currently displayed question. Both the original responses and the new responses are stored in the TurningPoint 2008 session file.</p> <p>If the slide show had previous voting session data saved, it might open showing voting closed. To begin voting again, select the Repoll Question button.</p>
Insert Slide		<p>Insert Slide allows you to insert a slide into a presentation that is currently open for voting. Pressing this button opens a drop-down menu allowing you to select the slide type to be inserted into the presentation. You are able to gather voting results on the inserted slide immediately.</p>
Toggle Results		<p>The Toggle Results button changes the values displayed on each results chart. The values can be represented as either numbers or percents. This button only works when a results chart is shown.</p>
Show/Hide Showbar		<p>The Show/Hide Showbar button opens and closes the TurningPoint 2008 Showbar. The Showbar contains the options available to the Voting Tool and also additional TurningPoint 2008 options.</p> <p>Refer to TurningPoint 2008 help for more information on the Showbar.</p>
Display Participant Monitor		<p>The Display Participant Monitor button opens the Participant Monitor.</p> <p>Refer to TurningPoint 2008 help for more information on the Participant Monitor.</p>
Show the Original Chart		<p>The Show the Original Chart button can be used after using the Toggle Results or Data Slicing buttons to return the chart to its appearance when it was first created.</p>

Open TurningPoint 2008 Help		Opens the TurningPoint 2008 help file.
Data Slicing		The Data Slicing button shows the responses on the chart for the portion of the audience who chose a certain response on another question. Refer to TurningPoint 2008 help for more information on data slicing.

Standard Annotation Toolbar

The standard annotation toolbar appears only when an interactive receiver or security key is not detected.

The tools on the standard annotation toolbar include (from left to right):

Marker		The Marker Tool allows you to annotate the displayed page freehand in one of four solid colors. The color can be selected from the palette that appears when the Marker Tool is selected. The marks become annotation elements. See Scrapbook Elements for more information.
Highlighter		The Highlighter Tool allows you to annotate the displayed page freehand in one of four transparent colors. The color can be selected from the palette that appears when the Highlighter Tool is selected. The marks become annotation elements. See Scrapbook Elements for more information.
Eraser		The Eraser Tool allows you to erase an annotation element made by the marker or highlighter tool on a Scrapbook page. The eraser size can be selected from the palette that appears when the Eraser Tool is selected. See Scrapbook Elements for more information.
Zoom		The Zoom Tool allows you to adjust the viewing size of the displayed page. The range of zoom values are 25-2000%. Holding down the Shift key reverses the zoom direction. A zoom value can also be selected from the pull-down list that appears when the Zoom Tool is selected.
Text		The Text Tool allows you to add a text box to a page in any size, font and color available on your computer. The size, font and color may be selected from the palette that appears when the Text Tool is selected. See Text Tool for more information.
Pointer		The Pointer Tool allows each participant in a meeting to point to data anywhere within the meeting window. Each participant's pointer is displayed in a different color. The Pointer Tool is only enabled during a shared meeting. The Pointer direction (right, left, up, down) can be selected from the palette that appears when the Pointer Tool is selected. You can also hide the Pointer by selecting the Hide Pointer button from the palette that appears when the Pointer tool is selected.
Shapes		The Shapes Tool allows you to draw shapes in Scrapbook. The shape, color and line width can be selected from the palette that appears when the Shapes Tool is selected. The marks become Shape elements. See Scrapbook Elements for more information.
Select		The Select Tool allows you to select a Scrapbook element on a page to move, rotate, resize, group or copy. To select a Scrapbook element, click the element and handles will appear. The Select Tool can also be used to draw a bounding rectangle around a group of elements to manipulate the entire group of elements at one time. For more information about working with Scrapbook elements, see Scrapbook Elements .

eBeam Home

eBeam Education Suite software comes with the eBeam Home application. eBeam Home is your resource for creating a centralized area for shortcuts to the programs and files that you use most often. The following topics are available for eBeam Home:

To learn about more about working with shortcuts, see [eBeam Home Shortcuts](#).

Launching eBeam Home

You can launch eBeam Home in the following ways:

- Click on the software icon in the eBeam Education Suite software folder installed in the Application Files on your computer.
- Select eBeam Home from the [eBeam Education Taskbar Menu](#).

You can also create a shortcut to eBeam Home on your computer desktop and launch the application by clicking this shortcut.

Note: Launching eBeam Home will also launch the eBeam Tool Palette.

Hiding eBeam Home

You can hide eBeam Home in the following ways:

- Click on the close button  in the top corner of your eBeam Home Window.
- Right-click anywhere outside of a shortcut within the eBeam Home Window and select Close eBeam Home.
- Select eBeam Home from the [eBeam Education Taskbar Menu](#).

Whenever you click on a shortcut in eBeam Home, the eBeam Home Window will hide, and your application, file or folder will launch. In order to see the eBeam Home Window again you will need to relaunch it.

eBeam Home Shortcuts

eBeam Home Shortcuts

There are nine default shortcuts included in eBeam Home. You can customize these shortcuts at any time, up to 25 shortcuts. If there are multiple users on your computer, these shortcuts will be saved per user account. The following shortcut topics are available with eBeam Home:

- [Adding a Shortcut](#)
- [Removing a Shortcut](#)
- [Renaming a Shortcut](#)
- [Reordering Shortcuts](#)
- [Broken Shortcuts](#)
- [Restoring Shortcuts](#)
- [Restoring Default Shortcuts](#)

Adding a Shortcut

You can add a shortcut to your eBeam Home Window by either using the Add Shortcut Button, or by dragging your shortcut.

To Use the Add Shortcut Button:



1. Click the Add Shortcut Button from the bottom left corner of your eBeam Home Window, and select Add Hyperlink or Add Shortcut.
2. If you select hyperlink, type or paste the hyperlink you would like to add, and click OK. If you select shortcut, browse for the shortcut you would like to add and select OK.

To Drag the Shortcut:

1. Find the file, folder or webpage that you would like to add as a shortcut.
2. Click and drag the the file, folder, or webpage to the eBeamHome Window and release your cursor anywhere inside the window.

Note: If you already have 25 shortcuts and you try to add another, you will receiver an error dialog box. Click OK to exit the error dialog box, and remove a shortcut before attempting to add another one.

Removing a Shortcut

You can remove a shortcut from your eBeam Home Window in the following ways:

Right-Click Shortcut

1. Right-click on the shortcut in your eBeam Home Window, and select Remove Shortcut.
2. Select Yes from the dialog box that appears.

Hover Over Shortcut

1. Hover over the shortcut in your eBeam Home Window and a Remove Icon appears . Click this icon.
2. Select Yes from the dialog box that appears.

Renaming a Shortcut

You can rename a shortcut at any time. To rename a shortcut:

- Right-click on the shortcut and select Rename.
- Single click on the shortcut text.

The shortcut text will become an editable field. Enter the new shortcut name and click outside of the text field or press Enter.

Reordering Shortcuts

You can reorder the shortcuts in your eBeam Home Window at any time. To reorder the shortcuts:

1. Press and hold your cursor over a shortcut
2. Drag your cursor to the new location and release.

Broken Shortcuts

If you move, rename or delete a file, folder or application that links to an eBeam Home shortcut, you will create a broken shortcut. Clicking on a broken shortcut will produce an error dialog box. From this dialog box you can search for the moved or renamed file, folder or application and create a new shortcut.

Restoring Shortcuts

If you replace a file, folder or application that links to an eBeam Home shortcut without changing the name of either the shortcut or the linked file, the broken link will be restored and your shortcut will work again.

Restoring Default Shortcuts

If you would like to restore the eBeam Home Window to its default set of shortcuts, right-click anywhere within the eBeam Home Window outside of a shortcut and select Restore Default Shortcuts. In the dialog box that appears, select which default shortcuts you would like to restore. You can select from:

- All shortcuts
- Only those shortcuts that were removed
- Cancel

Once you make your selection, the dialog box will disappear.

eBeam Scrapbook

Scrapbook Menus

[File Menu](#)

[Edit Menu](#)

[View Menu](#)

[Page Menu](#)

[Meetings Menu](#)

[Help Menu](#)

File Menu

File Menu options are described below:

<p>New</p>	<p>New creates a new Scrapbook meeting file after closing any previously opened meetings.</p> <p>To create a new Scrapbook meeting file:</p> <ol style="list-style-type: none"> 1. Choose File > New or press Ctrl+N. 2. If a meeting is open when New is chosen, Scrapbook prompts you to save the current meeting. Select Yes to save the meeting, No to close the meeting without saving or Cancel to remain in the current meeting. <p>A new meeting is created every time Scrapbook opens.</p>
<p>Open</p>	<p>Open allows you to open a Scrapbook (*.esb) file or an eBeam Capture (*.wbd) file. To open a Scrapbook file:</p> <ol style="list-style-type: none"> 1. Choose File > Open, or press Ctrl+O. A standard Open File dialog box appears. 2. Navigate to the *.esb file and select that file. 3. Select OK.
<p>Import/Merge</p>	<p>Import/Merge allows you to:</p> <ul style="list-style-type: none"> • Import an Excel, PowerPoint or Word file to the background of the currently selected page, or • Merge an existing Scrapbook (*.esb) or Capture (*.wbd) file to the currently open file. <p>Note: Import/Merge is disabled during shared meeting.</p>
<p>Save</p>	<p>Save allows you to save a Scrapbook (*.esb) file. To save a Scrapbook file:</p> <ol style="list-style-type: none"> 1. Choose File > Save, or press Ctrl+S. 2. If the file has been saved before, it is saved again under the existing name. <p>If this is the first time the meeting has been saved, the standard Save As dialog box opens.</p>
<p>Save As</p>	<p>Save As allows you to save a new Scrapbook (*.esb) file or to save an existing Scrapbook meeting file under a new name.</p> <p>To save a Scrapbook file:</p> <ol style="list-style-type: none"> 1. Choose File > Save As. The standard Save As dialog box opens. 2. Enter a meeting name and select the folder location. The default folder location is under My Documents in My Scrapbook. 3. Select the file type. 4. Select the range of pages you want to save: <ul style="list-style-type: none"> ○ All - Saves all pages. The default range is All pages. This is also the only option available when the Scrapbook file has only one page. ○ Selected - Saves only selected pages. You can select multiple pages by clicking on each Thumbnail while holding down the Ctrl key, then saving the document.

	<ul style="list-style-type: none"> ○ Pages - Allows you to select a range of pages to save. <p>Note: If you have not previously saved the file, any unselected pages will be lost when you use the Selected or Pages options and are saving to either *.esb or *.wbd.</p> <p>5. Select OK.</p>
Save As Web Page	<p>Save As Web Page allows you to save a Scrapbook (*.esb) meeting file in HTML format for posting to the Internet/intranet as a web page.</p> <p>To save a Scrapbook file in HTML format:</p> <ol style="list-style-type: none"> 1. Choose File > Save As Web Page. The Save As dialog box appears. 2. Enter a meeting name and select the folder location. The default folder location is under My Documents in My Scrapbook. 3. Select the range of pages you want to save: <ul style="list-style-type: none"> ○ All - The default range is All pages. This is also the only option available when the Scrapbook file has only one page. ○ Selected - Saves only selected pages. You can select multiple pages by clicking on each Thumbnail while holding down the Ctrl key, then saving the document. ○ Pages - Allows you to select a range of pages to save. 4. Select Save.
Archive Meeting	<p>Archive Meeting allows you to archive your Scrapbook meeting file on an eBeam server.</p> <p>See Archive a Meeting for more information.</p>
Retrieve Meeting	<p>Retrieve Meeting allows you to retrieve an archived Scrapbook meeting file from an eBeam server.</p> <p>See Retrieve a Meeting for more information.</p>
Page Setup	<p>Page Setup opens the Page Setup dialog box. The Page Setup dialog box allows you to choose header and footer information for a printed Scrapbook page and allows you to add a border for the printed page.</p>
Print Setup	<p>Print Setup opens the standard Print Setup dialog box. The Print Setup dialog box allows you to select all desired printer settings, including portrait or landscape orientation and paper source.</p>
Print Page	<p>Print Page prints only the displayed page to your default printer.</p>
Print	<p>Print opens the standard Print dialog box. This dialog allows you to select a page range and the number of copies you want to print. The default settings are to print all pages in the file and to print one copy.</p> <p>To print the Scrapbook file, choose File > Print or press Ctrl+P.</p>
Send	<p>Send allows you to send a Scrapbook meeting file (*.esb) as an attachment via any MAPI-compliant mail system, such as Microsoft Exchange.</p> <p>To send a Scrapbook meeting file via email:</p> <ol style="list-style-type: none"> 1. Choose File > Send. The Send dialog box appears. 2. Select the file format and page range from the Send dialog box 3. Select OK. <p>Scrapbook opens an untitled e-mail message in your MAPI-compliant mail program</p>

	<p>with your file as an attachment. Use your address book to fill in names of the recipients and send the email as you normally would.</p> <p>You can send a Scrapbook meeting in any file format (except HTML) that is suitable for an e-mail attachment.</p>
Send to Kindle	<p>Send to Kindle allows you to send a Scrapbook meeting file in PDF, JPG or BMP format to your Kindle device as an attachment via any MAPI-compliant mail system, such as Microsoft Exchange.</p> <p>To send a Scrapbook meeting file to Kindle:</p> <ol style="list-style-type: none">1. Choose File > Send to Kindle The Send to Kindle dialog box appears.2. Select the file format and page range from the Send to Kindle dialog box.3. Type the email address for your Kindle device into the E-mail text field.4. Select OK. <p>Scrapbook opens an e-mail message titled Kindle in your MAPI-compliant mail program with your file as an attachment. Use your address book to fill in names of the recipients and send the email as you normally would.</p>
Exit	<p>Exit closes Scrapbook, but does not close the eBeam Tool Palette. See the eBeam Education taskbar menu for more information.</p> <p>If you have not saved your Scrapbook file, you will be prompted to save the file before Scrapbook closes.</p>

Edit Menu

Edit Menu options are described below:

<p>Undo</p>	<p>Undo cancels the last change on a Scrapbook page. It is possible to undo all changes to return the Scrapbook page to a totally empty state. Undo applies only to the current page.</p> <p>To Undo:</p> <ul style="list-style-type: none"> ● Choose Edit > Undo, or ● Select the Undo button from the Scrapbook Toolbar, or ● Press Ctrl+Z.
<p>Redo</p>	<p>Redo allows you to redo the last undone change. If you have used Undo multiple times, you can redo the changes back to the beginning of the series. Redo is disabled once a new change has been made to the page. Redo applies only to the current page.</p> <p>To Redo:</p> <ul style="list-style-type: none"> ● Choose Edit > Redo, or ● Select the Redo button from the Scrapbook Toolbar, or ● Press Ctrl+Y.
<p>Cut</p>	<p>Cut is used to cut individual or grouped Scrapbook elements from a Scrapbook page or with the Text Tool to cut text from active text boxes. These cut elements and text can then be pasted to a new Scrapbook page or active text box.</p> <p>To cut an element from a Scrapbook page:</p> <ol style="list-style-type: none"> 1. Use the Select Tool to select the element(s) to cut. 2. Choose Edit > Cut, or press Ctrl+X. 3. Paste to another Scrapbook page, or open another application such as MS Word or MS Paint and paste. <p>To cut text from text box:</p> <ol style="list-style-type: none"> 1. Highlight the text in the text box. 2. Choose Edit > Cut, or press Ctrl+X.
<p>Copy</p>	<p>Copy allows you to copy individual or grouped Scrapbook elements from a Scrapbook page to other Scrapbook pages or applications. It can also be used with the Text Tool to copy and paste text within active text boxes.</p> <p>To copy an element from a Scrapbook page:</p> <ol style="list-style-type: none"> 1. Use the Select Tool to select the element(s) to copy. 2. Choose Edit > Copy, or press Ctrl+C. 3. Paste to another Scrapbook page, or open another application such as MS Word or MS Paint and paste. <p>To cut text from text box:</p> <ol style="list-style-type: none"> 1. Highlight the text in the text box. 2. Choose Edit > Copy, or press Ctrl+C. <p>Notes:</p> <ul style="list-style-type: none"> ● You can also copy an element from one Scrapbook page to another by dragging the element

	onto a new thumbnail.
Paste	<p>Paste is used to paste Scrapbook elements into a Scrapbook page from either another Scrapbook page or from your computer's clipboard. It is also used with the Text Tool to cut and paste text between active Scrapbook text boxes.</p> <p>To paste an element:</p> <ol style="list-style-type: none"> 1. Cut or copy the individual or grouped elements from a Scrapbook page, the Gallery or an outside image file. 2. Select the Scrapbook page. 3. Choose Edit > Paste, or press Ctrl + V. <p>To paste text between active Scrapbook text boxes:</p> <ol style="list-style-type: none"> 1. Copy text from another Scrapbook text box. 2. Open a new text box. 3. Choose Edit > Paste, or press Ctrl + V. <p>Note: Text copied from other applications will be pasted into Scrapbook as an image element.</p>
Select All	<p>Select All allows you to select all Scrapbook elements in a page. The elements can be manipulated as one, but are not grouped.</p> <p>To select all:</p> <ul style="list-style-type: none"> • Choose Edit > Select All, or press Ctrl+A.
Duplicate	<p>Duplicates the selected individual or grouped element(s).</p> <p>To duplicate an element:</p> <ol style="list-style-type: none"> 1. Use the Select Tool to select the element(s) See Select elements individually or in groups. 2. Choose Edit > Duplicate, or press Ctrl+D.
Delete	<p>Deletes the selected individual or grouped element(s).</p> <p>To delete an element:</p> <ol style="list-style-type: none"> 1. Use the Select Tool to select the element(s) and use one of the following methods to delete the object: <ul style="list-style-type: none"> ○ Choose Edit > Delete, ○ Select the Delete Object button from the Scrapbook Toolbar or ○ Press the Delete key.
Order	<p>Order allows you to change the Z-order of the elements on your Scrapbook page. See Move an element forward or backward.</p>
Grouping	<p>Group is used to bond a selection of elements together so they can be manipulated as a single element. See Group and ungroup elements for more information.</p>
Alignment	<p>The Alignment menu allows you to access a sub-menu with Alignment and Distribute options.</p> <p>Alignment is used to align selected Scrapbook elements relative to each other. Distribute is used to distribute Scrapbook elements equal distances from each other.</p> <p>See also Align and Distribute elements.</p>
Orientation	<p>Orientation is used to rotate individual or grouped Scrapbook elements without changing the placement of the elements on page.</p> <p>To set the orientation of one or more Scrapbook elements:</p> <ol style="list-style-type: none"> 1. Use the Select Tool to select the element. 2. Select your orientation option from the Edit > Orientation menu. The options are: <ul style="list-style-type: none"> • Rotate Right: Rotates the element clockwise 90 degrees.

	<ul style="list-style-type: none">• Rotate Left: Rotates the element counter-clockwise 90 degrees.• Flip Vertical: Flips the element vertically.• Flip Horizontal : Flips the element horizontally.
Reset Image Properties	Change the selected element back to the size it was when it was brought into the application.
Options	Options opens the Scrapbook Options dialog box, displaying the following tabs: <ul style="list-style-type: none">• Preferences• Proxy Server• Software Updates

View Menu

View Menu options are described below:

Normal (View Page and Thumbnails)	<p>Normal allows you to switch to the Page and Thumbnails View. Switch to the Page and Thumbnails View by:</p> <ul style="list-style-type: none"> • Choosing View >Normal, or • Pressing Ctrl+1, or • Selecting the View Page and Thumbnails (Normal) button from the Scrapbook Toolbar
Thumbnails	<p>Thumbnails allows you to switch to the Thumbnails View. Switch to the Thumbnails View by:</p> <ul style="list-style-type: none"> • Choosing View >Thumbnails, or • Pressing Ctrl+2, or • Selecting the View Thumbnails button from the Scrapbook Toolbar
Page	<p>Page allows you to switch to the Page View. Switch to the Page View by:</p> <ul style="list-style-type: none"> • Choosing View >Page, or • Pressing Ctrl+3, or • Selecting the View Page button from the Scrapbook Toolbar
Gallery	<p>Gallery opens Scrapbook's Integrated Clip-Art Gallery. Open the Gallery by:</p> <ul style="list-style-type: none"> • Choosing View > Gallery, or • Pressing Ctrl+4, or • Selecting the Gallery button from the Scrapbook Toolbar <p>You can use this feature to add graphics from the provided library of clip art to your presentations. You can also add your own directories to the gallery. See Gallery, Scrapbook Elements, and Background Settings for more information about using images.</p>
Full Screen View	<p>Full Screen View maximizes the current page to full screen size.</p> <p>To go to full screen:</p> <ul style="list-style-type: none"> • Choose View >Full Screen View, or • Select the Full Screen button from the Scrapbook Toolbar <p>To return to normal screen size:</p> <ul style="list-style-type: none"> • Right-click the screen (press the Tool Palette button on the Interactive Stylus), and select Full Screen Off from the menu that appears, or • Select the Full Screen button from the Scrapbook Toolbar
Use Cover Sheet	<p>Use Cover Sheet allows you to cover all or part of your page. You can size the sheet during your presentation as well as set its orientation and transparency.</p>
Spotlight	<p>Spotlight is useful for drawing attention to a particular region of your desktop.</p>
eBeam Focus Viewer	<p>eBeam Focus Viewer launches the eBeam Focus Document Camera viewer.</p>
Participants	<p>Participants opens the Participants window so you can see who has joined a shared Scrapbook meeting. To open the Participants window:</p> <ul style="list-style-type: none"> • Choose View >Participants, or • Press Ctrl+5, or • Select the Participant View button from the Scrapbook Toolbar
Master Page	<p>Master Page opens the master page. All changes made to the master page appear as a background image on all Scrapbook pages except those that contain their own background settings.</p> <p>Open the Master Page by:</p>

	<ul style="list-style-type: none"> • Choosing View >Master Page, or • Pressing Ctrl+6.
Layers	<p>Layers can be used to add content to a Scrapbook meeting file. Layers can be hidden or shown.</p> <p>Open the Layers by:</p> <ul style="list-style-type: none"> • Choosing View >Layers, or • Pressing Ctrl+7.
Toolbar	<p>Choosing the Toolbar option causes a sub-menu to open with the following three selections:</p> <ul style="list-style-type: none"> • Interactive Tools : Show/hide the Tool Palette. • Playback: Show/hide thePlayback toolbar. • Status Bar: Show/hide the Scrapbook status bar.
Zoom To	<p>Zoom To allows you to zoom in or out on the currently displayed page.</p> <p>Choosing the Zoom To menu option causes a sub-menu to open with the following zoom selections: 500%, 300%, 200%, 100%, 50%, and 25%.</p> <p>The page will remain at the selected zoom value until a new zoom value is chosen.</p>
Zoom In	<p>Zoom In allows you to zoom in on the currently displayed page.</p> <p>To zoom in on a page:</p> <ul style="list-style-type: none"> • Choose View >Zoom In, or • Press Ctrl+Num +.
Zoom Out	<p>Zoom Out allows you to zoom out on the currently displayed page.</p> <p>To zoom out of a page:</p> <ul style="list-style-type: none"> • Choose View >Zoom Out, or • Press Ctrl+Num -.
Fit Page	<p>Fit Page compresses or expands the page to fit into the page display area. Fit Page can also be selected by pressing Ctrl+0.</p>
Actual Size	<p>Actual Size zooms the Page to 100%.</p>

Cover Sheet

Cover Sheet is useful for hiding page content and gradually revealing presentation points during a lesson or meeting.

To start Cover Sheet, select [View](#) > Use Cover Sheet. You can now control the display of Scrapbook page content and customize the Cover Sheet.

When the Cover Sheet is visible, the page area of the Scrapbook is grayed out; thumbnails are not affected. You can uncover more of any page by dragging the covered area in the direction you wish it to move. Dragging affects only the page you are viewing.

The cover sheet always fully covers a page until you uncover a section of the page. Cover Sheet options (Transparency and Rotation) you set remain in effect on all pages.

You can interact normally with the Scrapbook in the lighted area. Markups that begin in the lighted area will continue into the covered area.

The Cover Sheet has the following control menus.

Options	<ul style="list-style-type: none"> ● Transparency: This option allows you to select how dark the grayed out area will be. <ul style="list-style-type: none"> <input type="radio"/> 30% - lightest <input type="radio"/> 20% - lighter <input type="radio"/> 10% - light <input type="radio"/> 0% - completely opaque ● Rotate: This option allows you to rotate the cover sheet so you can expose different areas of the screen. <ul style="list-style-type: none"> <input type="radio"/> Clockwise by 90 deg. <input type="radio"/> Counter-clockwise by 90 deg.
Exit (X)	Closes the Cover Sheet feature.

Master Page

Master Page is used to create a background template for all pages in the Scrapbook meeting, except for those pages containing their own [background settings](#).

Open the Master Page by choosing [View](#) > Master Page in Scrapbook. The Master Page will open the first time as a blank page.

Any changes made to the Master Page, such as [background settings](#), adding [layers](#), [annotating](#) the page or adding [Scrapbook elements](#) are reflected as the background on all pages in the Scrapbook meeting, except for those pages containing their own [background settings](#).

The Master Page contents:

- will be set as the background on all new pages.
- will not overwrite the background on existing pages that already contain [background settings](#).
- will overwrite the background on existing pages that have content, but do not contain [background settings](#).

To clear the Master Page, remove all background images using [Background Settings](#), and use the Clear Page button from the Master Page toolbar to clear all elements.

Close Master Page Button

Close Master Page closes the Master Page and returns to annotating regular Scrapbook Pages.

Layers

The following section describes Layers and how to use them in your Scrapbook meeting.

- [What are Layers?](#)
- [How to Use Layers](#)

What are Layers?

Every Scrapbook page is made up of layers that can be shown or hidden at any time. The order of these layers are:

- Page Background Layer: The page background can be set using [Background Settings](#) to display an image, display a template of a grid or horizontal lines, and/or be set to a specific background color. The page background cannot be modified by the annotation tools.
- Annotation Layers: The annotation layers are transparent layers that are stacked on top of the page background layer. These layers contain [Scrapbook elements](#).

Any Scrapbook page can have multiple annotation layers. When you add a new layer, it is stacked on top of the existing layers. This means that annotations are displayed with the latest layer shown at the top.

The three types of annotation layers that are found in each Scrapbook page are:

- Default Layer: The default annotation layer in the Scrapbook page. This layer always exists for any Scrapbook page and cannot be deleted.
- User Layers 1 - 18: Up to 18 additional layers can be added to a Scrapbook page. The default layer and the user layers are always shared to remote participants during a shared meeting.
- Private Layer: The top-most layer is the private layer. The private layer is shown only on the local computer and is never shared through a shared meeting. The purpose of the private layer is to give the local user a private workspace within the Scrapbook session. Note: Private layers are hidden when a shared meeting is synchronized.

All annotation layers can be locked and/or shown/hidden.





How to Use Layers

Turn on layers by choosing Layers from the [View Menu](#). This opens the Layers dialog box that lets you select, add, delete and move layers of a Scrapbook page.

Layers Title Bar



The Layers dialog title bar indicates which Scrapbook page you are currently working in.

Layers Tools

Add Layer		Add Layer adds a new blank layer to the currently selected Scrapbook page. The new layer is always added as the top-most layer (under the user layer). The new layer is always added as visible and unlocked.
Delete Layer		Delete Layer causes the selected layer to be deleted. It is not possible to delete the private or default layers.
Move Layer Up		Move Layer Up causes the layer to be moved one level higher in the layer list. The highest a layer can be moved is directly below the private layer. The private and default layers cannot be moved.
Move Layer Down		Move Layer Down causes the layer to be moved one level lower in the layer list. The lowest a layer can be moved is directly above the default layer. The private and default layers cannot be moved.

Layers - Layer List

Each layer has it's own settings. These settings are described in the table below.





Show/Hide		Show/Hide makes the layer visible/invisible. When the eye is shown in the box, the layer is visible on the page. When the box is empty, the layer is invisible.
Lock Layer		Lock Layer protects the layer from any new annotations. When the padlock is shown in the box, the layer is locked. When the box is empty, it is possible to add Scrapbook elements to the layer.

Playback

The Playback Toolbar can be opened by choosing [View](#) > Toolbar > Playback.

The Playback Toolbar allows you to replay the meeting like a movie. The meeting can be played forward line by line and at varying speeds. Playback can be restricted to either the current page, or set to play all pages.

The following Playback tools are available on the Playback Toolbar.

Jump to Beginning		Jumps to the beginning of the Scrapbook meeting (if All Pages is checked) or to the beginning of the selected page.
Drag Control Slider		Allows you to step through the meeting forward or reverse by using the Interactive Stylus or your mouse to drag the drag bar on the drag line, or to immediately jump to a specific point in the meeting by dragging the drag bar to a location on the drag line.
Play		Replays the entire Scrapbook meeting (if All Pages is checked) or the selected Page from beginning to end. During playback, the Play button changes to a Stop button, allowing you to stop the playback.
Jump to End		Jumps to the end of the Scrapbook meeting (if All Pages is checked) or the beginning of the selected page.
All Pages	<input checked="" type="checkbox"/> All Pages	Sets the number of pages played. If All Pages is checked, selecting Play causes the entire meeting to be played back. If All Pages is not checked, only the currently displayed page is played back. You also can set this option in the Page > Playback sub-menu.
Loop	<input checked="" type="checkbox"/> Loop	Option for looping through the entire Scrapbook meeting (if All Pages is checked) or for looping the selected page. You also can set this option in the Page > Playback sub-menu.
Play Speed	1x 	Sets the speed at which the meeting is played. The slowest speed is 0.5x; the fastest speed is 8.0x. You also can set this option in the Page > Playback sub-menu.

Note: Playback is enabled only when the Page and Thumbnails View or Page View are selected.

Spotlight

The Spotlight is useful for drawing attention to a particular region of your desktop.

To start Spotlight select the Spotlight menu item in the eBeam Education [taskbar menu](#) or from the Scrapbook Toolbar.

You can now highlight a specific area of your desktop and use the Spotlight Options menu to customize the spotlight.

To move the spotlight, click in the grayed-out area, then drag. Clicking in the spotlight lets you interact normally with the desktop items in the spotlight area.

Spotlight's Options menu can be found in the top right corner of the screen.

Options	Spotlight options you set remain in effect until you reset them. <ul style="list-style-type: none">● Transparency: This option allows you to select how dark the grayed out area surrounding the spotlight will be.● Spotlight shape: This option allows you to select the shape of the spotlight.● Spotlight size: This option allows you to select the size of the spotlight.
Exit (X)	Closes the spotlight feature.

Page Menu

Page Menu options are described below:

New	<p>New creates a new blank page in the Scrapbook meeting.</p> <p>To create a new page:</p> <ul style="list-style-type: none"> ● Choose Page >New , or ● Select the New Page button from the Scrapbook Toolbar <p>The new page is inserted directly after the displayed page.</p>
Clear	<p>Clear clears all elements from the displayed page.</p> <p>To clear a page, select the page to be cleared and:</p> <ul style="list-style-type: none"> ● Choose Page >Clear, or ● Select the Clear Page button from the Scrapbook Toolbar
Duplicate	<p>Duplicate creates a copy of the displayed page and makes the copy the displayed page.</p> <p>To duplicate a page, select the page to be duplicated and:</p> <ul style="list-style-type: none"> ● Choose Page > Duplicate, or ● Select the Duplicate Page button from the Scrapbook Toolbar <p>The duplicated Page is inserted directly after the displayed Page.</p>
Delete	<p>Delete deletes the displayed page.</p> <p>To delete a page, select the page to be deleted and:</p> <ul style="list-style-type: none"> ● Choose Page > Delete, or ● Select the Delete Page button from the Scrapbook Toolbar
Delete All	<p>Delete All deletes all pages from the Scrapbook meeting. All data will be lost.</p>
Next Page/Previous Page	<p>Next Page navigates to the next page in the Scrapbook meeting. This option is available only when the last page in the meeting is not displayed.</p> <p>To select Next Page:</p> <ul style="list-style-type: none"> ● Choose Page >Next Page, or ● Select the Next Page button from the Scrapbook Toolbar or ● Press the Page Down button on your keyboard. <p>Previous Page navigates to the previous page in the Scrapbook meeting. This option is available only when the first page in the meeting is not displayed.</p> <p>To select Previous Page:</p> <ul style="list-style-type: none"> ● Choose Page >Previous Page, or ● Select the Previous Page button from the Scrapbook Toolbar or ● Press the Page Up button on your keyboard.
Go To Page	<p>Go To Page allows you to select the page to be displayed by typing in or selecting a page number.</p> <p>To go to a page:</p> <ol style="list-style-type: none"> 1. Choose Page >Go To Page to open the Go To Page dialog. 2. Select a page using the up-and-down arrow buttons, or type the page number into the text box. 3. Select OK. <p>Or:</p>

	Use the Page Selection tools on the Scrapbook Toolbar.
Playback	See Playback for more information.
Add Hyperlink	Add Hyperlink allows you to add a hyperlink to a Scrapbook element. See Hyperlinked elements and Scrapbook elements for more information.
Add Image	Add Image allows you to import an image file or screen capture into the currently selected page. See Scrapbook elements for more information.
Add Flash File	Add Flash File allows you to import a Flash file (*.swf) or Flash movie (*.flv) into the currently selected page. See Scrapbook elements for more information.
Add Snapshot	Add Snapshot allows you to import a screen shot.
Background Settings	Background Settings allows you to: <ul style="list-style-type: none"> ● Import an image file or screen capture to the background of the selected page. ● Set the background color and transparency of a page. ● Add a grid or horizontal lines to the selected page.
Add Page to Templates	When you select Add Page to Templates , a copy of the entire page and all its contents is saved as a template in the Templates folder.

Meetings Menu

Meetings Menu options are described below:

Share/End Meeting	Share Meeting allows a meeting host to share a Scrapbook meeting over the Internet/intranet. While a meeting is shared, this menu option changes to End Meeting.
Join Meeting/Leave Meeting	Join Meeting allows invited participants to log into a shared Scrapbook meeting. The participant will need to know the meeting name and a password (if applicable) prior to attempting to log in to the meeting. While participating in a meeting, this menu option changes to Leave Meeting.
Send Invitation	Send Invitation allows the meeting host to send e-mail invitations to all invited participants for the shared Scrapbook meeting.
Allow Annotations	Allow Annotations allows the host to decide whether or not to allow the Participants to add annotations in the shared Scrapbook meeting.
Synchronize Participants	Synchronize Participants allows the meeting host to keep the participants on the same page. While Synchronize Participants is on, the host controls which page is displayed.

Help Menu

The Help Menu opens a sub-menu that allows you to access help and also provides links to various registration and support pages that are provided by the hardware manufacturer of your interactive system.

Scrapbook Features

Scrapbook Elements

The content of a Scrapbook page is made up of several types of objects known as elements. These elements are annotations, shapes, text boxes, image files and Flash files. Each element is selectable using the Select Tool.

See the following topics:

- [What is a Scrapbook Element?](#): This topic defines the Annotation, Shapes, Text Box, Image File and Flash file elements.
- [How to Use Scrapbook Elements](#): Describes things you can do with Scrapbook elements, such as moving, duplicating, locking, etc.

What is a Scrapbook Element?

Scrapbook elements are described in the following table.

Element	Description
Annotations	<p>Annotations are lines drawn on the Scrapbook page using the Pen Tool or Highlighter Tool. Once drawn, the line becomes an element that can be moved, rotated, resized, grouped, etc.</p> <p>Annotation lines are automatically grouped with other lines based on how closely the annotations are drawn together and the elapsed time between the drawing of the lines. Grouping is done to preserve groups of lines that are meant to stay together, such as letters, numbers, shapes, etc.</p> <p>Autogrouping can be turned on or off in the Scrapbook Options dialog. Uncheck Autogroup pen and highlighter strokes to turn grouping off. See Group and ungroup an element.</p> <p>Annotations can not be modified using the Scrapbook Elements Edit Toolbar (a.k.a. the Object Edit Tools).</p>
Shapes	<p>Shapes are drawn on the Scrapbook Page using the Shapes Tool. Once drawn, the shapes becomes an element that can be moved, rotated, resized, grouped, etc.</p> <p>Notes:</p> <ul style="list-style-type: none"> • Shapes cannot be modified using the Scrapbook Elements Edit Toolbar (a.k.a. the Object Edit Tools). • Shapes cannot be erased using the Eraser Tool. • When adding a hyperlink to a shape, the hyperlink icon may not always appear on the shape but may instead appear near the shape.
Text Boxes	<p>A text box is an element that displays typed text on the Scrapbook page. Text boxes have their own edit toolbar. See Text Tool for more information.</p>
Image Files	<p>Image files, such as JPG and GIF images, can be imported into the Scrapbook page as elements.</p> <p>To import an image file as an element:</p> <ul style="list-style-type: none"> • Choose View > Gallery, or select the Gallery icon on the Scrapbook Toolbar to open the Gallery. The Gallery allows you to import an image file from a directory as a Scrapbook element or as a Background. If you choose Import As Object, the picture you select appears on your page as an element that you can manipulate. • Choose Page > Add Image to browse your computer to find the image filename. • Drag-and-drop the image file from your desktop or Explorer directly onto the Scrapbook page. • You can also drag and drop some types of files, such as Excel, Word and PowerPoint from your desktop onto a Scrapbook page and work with the resulting images as elements. In

	<p>multipage files, you will be prompted to select the page to use. See Background Settings for information on how to import multipage files as background images.</p> <ul style="list-style-type: none"> • Take a snapshot of your screen. <p>Supported file formats for image files:</p> <ul style="list-style-type: none"> • Bitmap (*.bmp) • Graphic Files (*.gif, *.jpg, *.ico, *.emf, *.wmf, *.png) • Excel Spreadsheets (*.xls). See Import a PowerPoint, Excel and Word Document • PowerPoint Presentations (*.ppt). See Import a PowerPoint, Excel and Word Document • Word Document (*.doc, *.rtf). See Import a PowerPoint, Excel and Word Document <p>Notes:</p> <ul style="list-style-type: none"> • Excel, PowerPoint and Word documents can only be loaded as elements one page at a time. To load more than one page at a time, see Background Settings • If you attempt to load a file type that is not supported the page will display a file icon and filename, but will not attempt to load that file into the page.
Flash Files	<p>Flash file in *.swf (Flash file) and *.flv (Flash movie) formats can be imported into the Scrapbook page as elements.</p> <p>Scrapbook will automatically embed play controls into your Flash element so you can use them with your Select tool to play, pause, rewind or fast forward the movie. There is also a progress bar which you can use to move to any particular point in the playback.</p> <p>To import Flash into a Scrapbook page:</p> <ul style="list-style-type: none"> • Choose Page >Add Flash File and select the file in the Open dialog box, or • Drag-and-drop the Flash file onto your Scrapbook page. <p>Notes:</p> <ul style="list-style-type: none"> • The entire Flash file will be embedded into your Scrapbook file so it can greatly increase your file size. • Due to the size of the Flash elements, they are not displayed during a shared meeting. A container will appear in the participant page, but video will not run. • Flash elements can not be grouped, added to the Master Page, deleted using the Del key modified using the Scrapbook Elements Edit Toolbar (a.k.a. the Object Edit Tools).

How to Use Scrapbook Elements

See the following Scrapbook elements topics:

- [Select Individual or Multiple Elements](#)
- [Manipulate Elements \(using the Edit Menu\)](#)
- [Lock \(protect\) an Element](#)
- [Move, Rotate and Resize Elements](#)
- [Align and Distribute Elements](#)
- [Order Elements](#)
- [Group and Ungroup Elements](#)
- [Use the Scrapbook Elements Edit Toolbar](#)
- [Hyperlink a Scrapbook Element](#)

Select Individual or Multiple Elements

Most operations on an element require that you select the element first. When an element is selected it will have drag handles and a rotate handle.

Select an element by choosing the **Select Tool** and then clicking the element in the Scrapbook page. To deselect an element use the **Select Tool** and click anywhere outside of the element's bounding box.

To select multiple elements draw a rectangle around the elements with the **Select Tool** or click multiple elements individually while holding the **Ctrl** key. The elements are selected but are not grouped.

To select all elements on a Scrapbook page at once:

- o Select **Edit > Select All**, or
- o Right-click (press the [Tool Palette button](#) on your Interactive Stylus) on the page and select **Select All**, or
- o Press **Ctrl+A** on your keyboard.

Lock (protect) an Element

Locking a Scrapbook element protects it from being modified in any way. Once an element is locked it can be [hyperlinked](#) but it cannot be moved, rotated, resized, cut, copied, duplicated, deleted, ordered, grouped, aligned, oriented, edited or reset.

When an element is selected the drag and rotate handles are replaced with a black border and an image of a lock appears in the center of the element.

When you select a mixture of locked and unlocked elements, none of the selected elements can be manipulated. To modify locked elements they must first be unlocked.

To lock an element choose the [Select](#) tool, select the element and select **Lock > Lock** from your right-click menu.

To unlock a locked element, select the element and then select **Lock > Unlock** from your right-click menu.

Move, Rotate and Resize an Element

When moving or rotating multiple elements at one time, you must first select all the elements using the **Select Tool** and draw a rectangle around them to create a temporary group.

Move an element by dragging it to the new location. It is not necessary to first select the element if you are only moving a single element.



To rotate an element, first select the element and then tap and hold the top handle. The mouse cursor will change to circular arrows to indicate that you are ready to rotate the element(s). If you are rotating a group of elements you can grab the handle of any element in the group. Drag the handle clockwise or counter-clockwise to rotate.

Notes:

- During rotation the object is redrawn continuously. The smoothness of the rotation depends on the speed of the computer, so on slower computers the rotation will be less smooth.



To resize an element, first select the element and then tap and drag one of the square handles. The element will resize as you drag.

- Maintain Aspect Ratio: To maintain the element's aspect ratio while resizing, only drag using a corner drag handle.
- Ignore Aspect Ratio : To resize an element without maintaining the element's aspect ratio, drag using a side drag handle.

Align and Distribute Elements

Alignment is used to align selected Scrapbook elements relative to each other. Distribute is used to distribute elements equal distances from each other.

To align or distribute a group of elements, first use the [Select Tool](#) to select the elements. Then choose the alignment or distribute option from the [Edit](#) menu or from your right-click (press the [Tool Palette button](#) on your Interactive Stylus) menu.

Alignment Options

- Align Left: The elements will align vertically to the left edge of the left most object.
- Align Center: The elements will align vertically to the averaged center point of all the elements.
- Align Right : The elements will align vertically to the right edge of the right most element.
- Align Top: The elements will align horizontally to the top edge of the highest object.
- Align Middle: The elements will align horizontally to the averaged center point of all the elements.
- Align Bottom: The elements will align horizontally to the bottom edge of the lowest object.

Distribute Options

- Distribute Horizontally: The elements will be distributed evenly and horizontally between the center points of the left and right most elements.
- Distribute Vertically: The elements will be distributed vertically and evenly between the center points of the top and bottom elements.

Order Elements

Elements exist on a Scrapbook page in order. The last element added to a page will be on top of and may cover elements added previously. The order that elements are displayed in is referred to as the Z-order.

To move an element forward or backward in the Z-order, first you must select the element using the [Select Tool](#). Once an element is selected it can be moved in front of or behind other elements by choosing one of the following options from the [Edit](#) > Order menu: Bring to Front, Send to Back, Bring Forward, or Send Backward. You can also right-click (press the [Tool Palette button](#) on your Interactive Stylus) the Scrapbook page to find the Order menu.

Group and Ungroup an Element

Grouping is used to manipulate a group of elements at the same time. It causes a set of elements to behave as a single element, even while editing or resizing. A grouped set of elements cannot be ungrouped by using the Select Tool to select outside of the group.

To group elements together, use the Select Tool to draw a bounding rectangle around a group of elements, and then choose [Edit](#) > Grouping > Group or select Grouping > Group from your right-click menu.

To ungroup grouped elements, use the Select Tool to select the grouped element, and then choose [Edit](#) > Grouping > Ungroup or select Grouping > Ungroup from your right-click menu.

Note: Autogrouping can be turned on or off in the Scrapbook Options dialog. Choose Edit > Options and then click the Preferences tab. Uncheck Autogroup pen and highlighter strokes to turn grouping off.

Scrapbook Elements Edit Toolbar

Scrapbook includes an Object Edit Toolbar that can be used to modify the transparency of or to crop image elements.

The Object Edit Tools cannot modify Flash files, Annotation elements or Text Box elements.

Note: The Object Edit Tools can only be used on single elements. You cannot open the toolbar when you have selected multiple elements or have selected a grouped element.

To open the toolbar:

- Double-click a single element, or
- Use the Select Tool to highlight the element, then right-click and choose Edit.
- You can also Press the [Tool Palette button](#) on your Interactive Stylus.

Object Edit Toolbar

The Object Edit Toolbar contain the following tools:

- [Crop Tool](#)
- [Transparency Tool and Transparency Slider](#)

Crop Tool

The Crop Tool is used to remove the outer parts of an image element (see [Scrapbook Elements](#)).



The Crop Tool is the default tool selection when you open the Object Edit Tools.

When the Crop Tool is selected, crop handles appear at the corners of the selected Scrapbook element's bounding box; the cursor changes to cropping cursor while inside the bounding box.

To crop the Scrapbook element, move any of the crop handles. You will be able to see the entire image, although the part of the image you are cropping out will be shaded grey.

To close out of the Crop Tool, deselect the object.

If an error is made or you just want to restore the original image:

- Select Edit Menu > Reset Image Properties, or
- Choose Reset Image Properties from the Right-click menu (press the [Tool Palette button](#) on your Interactive Stylus).

Transparency Tool and Transparency Slider

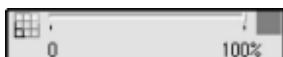

Transparency is used to render part of an image element transparent. This is useful for removing image backgrounds or similar functions. The transparency tools consist of the Transparency Dropper

and the Transparency Slider (shown to the left from left to right).



The Transparency Tool (dropper) is used to set individual colors transparent. When you use the Transparency Tool dropper to select a single color, it will render that color transparent as well as any color within 5 values of that color. (+/-, 5, 5 of RGB).

The Transparency Slider is used to globally set the transparency of the entire element at once.

If an error is made while using the Transparency tools or you just want to restore the original image:

- Select Edit Menu > Reset Image Properties, or
- Choose Reset Image Properties from the Right-click menu (press the [Tool Palette button](#) on your Interactive Stylus).

See the following transparency topics:

- [Set Single Color Transparency Within an Element](#)
- [Set Multiple Color Transparency Within an Element](#)
- [Set Transparency of an Element Using the Transparency Slider](#)

Set Single Color Transparency Within an Element

The default behavior of the Transparency Tool is to only render one color transparent at a time. If you set one color to transparent and then attempt to pick a new color to set transparent, the original color will be restored.

To set a single color transparent:

1. Select the element and open the Object Edit Tools.
2. Select the Transparency Tool (dropper button).

When the Transparency Tool is selected, the bounding box changes to have no handles; the cursor changes to the transparency dropper while inside the bounding box.

Note: The bounding box will only pick visible pixels as transparent pixels from the border or background will be automatically cropped.

3. Select a color within the selected Scrapbook element.

The selected color everywhere within the Scrapbook element is now transparent.

Set Multiple Color Transparency Within an Element

To set multiple colors to be transparent:

1. Follow the directions under Set single color transparency within an element.
2. Hold down either the Shift or Control Key while selecting the additional colors.

Set Transparency of an Element Using the Transparency Slider

You can adjust or set the global transparency of an element any time the Object Edit Tools are open regardless of the currently selected edit tool.

Use the Transparency Slider to select a setting between 100% (default) to 0% opaque.

Background Settings

Background Settings allow you to set a color, image or document as the background for any Scrapbook page. Scrapbook elements remain visible in front of the background settings, and during a shared meeting background Settings are displayed to all participants (see Share a meeting).

To open the Scrapbook Background Settings dialog box, select Background Settings from the Page menu in the Scrapbook window.

The Page Background can be set in the following ways:

- [Print to eBeam Scrapbook Image Writer](#) as a background,
- Import from [File](#) > Import/Merge ,
- Select Page > Background Settings to locate the [Background Settings](#) dialog box,
- Take a [snapshot](#) of your screen,
- Import images from the [Gallery](#) , or
- Set a [Master Page](#).

See [Supported File Formats](#) for information on which file types can be imported by Background Settings as a background image.

Using Background Settings

The Page > Background Settings option in Scrapbook allows you to:

- Import an image file, Excel, Word or PowerPoint file, screen captures or data from the clipboard as a background image on the selected page.
- Set any color for the background of the page.
- Turn on/off grid lines for that page (any imported background images remain in the background of the page).

The following table describes the Background Settings dialog box features.

Background Settings Options	<p>All options affect the displayed age or selected thumbnail in Scrapbook.</p> <ul style="list-style-type: none">• Load Background: Opens the standard Open dialog box. To load an image, navigate to and select the file you want to load into the page background and then select Open.• Load from Clipboard: Loads data from the computer's clipboard as the background image. If there is no data in the computer's clipboard, this button is disabled.• Remove Image: Removes the background image from the page. Any annotations will remain on the page.• File Scaling Options:<ul style="list-style-type: none">○ Do Not Scale: The file is imported into the background as is. This option is not available if the image size is bigger than the page size.○ Scale Proportionally: The file is scaled to fit as much of the page as possible.
-----------------------------	---

	<p>as possible while retaining the aspect ratio.</p> <ul style="list-style-type: none"> ○ Scale to Fit: The file is scaled to fit the page completely. The aspect ratio is not preserved. ○ Tile/Repeat: The file is tiled over the entire page. This option is not available for files with more than 1 page. This option is not available if the image size is bigger than the page size. <ul style="list-style-type: none"> ● Transparency: The Transparency of a background image on a page can be adjusted. Change the transparency of a single page background by opening the Background Settings dialog when that page is displayed and adjust the Transparency slider control in Options. Adjusting the transparency while importing a multi-page file will cause all pages in the file to be imported at the selected transparency level.
Background Settings Color	<p>The background of the page can be set to any Windows supported color.</p> <ul style="list-style-type: none"> ● Color: Select the Color checkbox to turn background color on. ● Solid: Select the Solid button to cause the background color to be displayed as a solid color. When Solid is selected, you can change the background color by selecting the Edit button. ● Gradient: Select the Gradient button to cause the background color to be displayed as a blend of two colors. When Gradient is selected, you can change the two colors to be blended by selecting either Edit button.
Background Settings Grid/Lines	<p>A Grid or Lines can be shown over any background color or image.</p> <ul style="list-style-type: none"> ● Grid/Lines: Select the Grid/Lines checkbox to turn background grid/lines on. ● Style: Select the Style pull-down list to choose a grid or horizontal lines. ● Line Width: Select the Line Width pull-down list to set the line width. ● Color: Select the Edit button to change the line color. ● Transparency: Set the transparency of the lines by adjusting the transparency slider control.

Supported File Formats for Background Settings:

- Bitmap (*.bmp)
- Graphic Files (*.gif, *.jpg, *.tif, *.ico, *.emf, *.wmf)
- Excel Spreadsheets (*.xls). See [Import a PowerPoint, Excel and Word Document](#).
- PowerPoint Presentations (*.ppt). See [Import a PowerPoint, Excel and Word Document](#).
- Word Document (*.doc, *.rtf). See [Import a PowerPoint, Excel and Word Document](#).
- If you attempt to load a file type that is not supported, the page will display a file icon and the filename but will not attempt to load that file into the page.

Hyperlinked Elements

A hyperlinked element is a Scrapbook element contained in a Scrapbook page that also contains a hyperlink. A hyperlinked element can be identified by the icon of a globe displayed in the bottom left corner of the element.

Use your Select Tool to select the globe icon on the element and your default web browser will open to the hyperlink URL address.

The following topics describe how to add, edit and remove hyperlinks when working with Scrapbook elements.

- Add a Hyperlink to an Element
- Edit or Remove a Hyperlink

Add a Hyperlink to an Element

1. Use the Select Tool to select the image or annotation element.
2. Choose [Page](#) > Add Hyperlink, or right-click on the element and choose Add Hyperlink to Object.
3. Choose the type of hyperlink you want to add by selecting one of the buttons (Web Page, Scrapbook Page or File).
 - For a Web Page type or paste a standard URL address, such as "http://www.luidia.com", into the Add Hyperlink dialog box.

Note : You must use one of the following prefixes in the URL:

http://
https://
ftp://
www.

- For a Scrapbook page, use the drop-down menu to choose one of the pages currently open in Scrapbook.
 - For a File, select the Browse button to navigate to the file to which you want to create a hyperlink.
4. Select the Add button. The image, annotation, shape or Flash element appears selected with a small globe icon in the corner.

Edit or Remove a Hyperlink

1. Use the Select Tool to select the image or annotation element.
2. Choose [Page](#) > Edit/Remove Hyperlink, or right-click on the element and select Edit/Remove Hyperlink. The Edit Hyperlink window displays.
3. Change the URL address and select the OK button, or click the Remove Hyperlink button.

Note: Remove Hyperlink will not delete the element.

Importing PowerPoint, Excel and Word Documents

This section covers procedures for importing PowerPoint, Excel and Word documents into Scrapbook. For more on how background images are used in Scrapbook, see [Background Settings](#).

Note: You must have Microsoft Office installed in order to import PowerPoint, Excel and Word documents into Scrapbook.

To import a PowerPoint, Excel or Word document into Scrapbook as a Background

1. In Scrapbook select [File](#) > Import/Merge or select [Page](#) > Background Settings, and use the Load Background button to locate the file.
2. Make sure you've selected the document type from the Files of type list, then navigate to and select the file you wish to import.
3. In the Import File dialog box, select one of the following choices
 - Load many images and use them for new pages—loads pages/sheets/slides that fall within the range you specify.
 - Load one image only and use it for the current page —loads one page/sheet/slide that you specify by its number.
 - Excel only: To load data from one sheet only, specify the sheet and the range of cells to be used. To load data from many sheets, specify the sheets to be used.
4. Select OK. The Import File dialog closes.
5. If you imported using the Background Settings dialog you should now select OK and Scrapbook imports the background according to the selections you made through the Background Settings import process.

See also:

- [Background Settings](#)
- [Improving PowerPoint Image Quality](#)

To import a PowerPoint, Excel or Word document into Scrapbook as an Object

1. Choose [Page](#) > Add Image
2. Make sure you've selected the type of file, then navigate to and select the file you wish to import.
3. There are different import options based on file type.
 - PowerPoint and Word Files: Select a page range. All pages in that range will be imported as a separate object.
 - Excel Files: Select a sheet. Only one sheet can be imported at a time.
4. Select OK. The Import File dialog closes.

See also: [Scrapbook Elements](#).

Improving PowerPoint Image Quality

The Scrapbook import typically decreases the file size of PowerPoint slides that contain high quality images by converting the images into a lower quality image format. This means that the images shown in Scrapbook are not as sharp or clear as the original PowerPoint slides.

If you want retain the high image quality of the original PowerPoint slides, do the following when importing to Scrapbook:

1. Choose [Edit](#) > Options.
2. Select the Preferences tab.
3. Check the Use original image quality checkbox found under PowerPoint Presentation Import.

Checking Use original image quality causes the high image quality of the original PowerPoint slide to be maintained as the file is imported into Scrapbook. However, checking this option also results in higher PC memory consumption and increases the time required to save, share and join meetings.

Exporting Documents into Scrapbook

Exporting Documents as Backgrounds and Objects

You can export documents into Scrapbook as backgrounds from any application that can print. This is a great option for PDFs and CAD drawings. For more on how background images are used in Scrapbook, see [Background Settings](#).

You can also export documents as objects (rather than backgrounds). See *Print documents to Scrapbook as objects* in [Scrapbook Options](#).

To export a document into Scrapbook as a Background

1. From your application (such as Word, Excel, PowerPoint, Acrobat, AutoCAD), choose File > Print. The Print dialog displays.
2. From the Print dialog, select eBeam Scrapbook Image Writer from the list of printers.
3. Specify print ranges as appropriate given the type of document you are working with, then click OK. Scrapbook immediately imports your document as a background image.

Gesture Based Navigation

Gesture Based Navigation (gesturing) is an advanced navigation style that allows you to navigate the various eBeam Tool palette using click-sweep motions of the [Interactive Stylus](#). Gesturing allows you to select between tools and tool properties without needing to have the Interactive Tools palettes visible on the screen.

See the following topics for more information.

- [Activate Gesture Based Navigation](#)
- [How Gesturing Works](#)
- [Mapping a Gesture to a Tool](#)
- [Mapping a Gesture to a Property](#)

Activate Gesture Based Navigation

To activate gesture based navigation, select the Options button from [eBeam Education Taskbar Menu](#), and select the Gesture Based Navigation checkbox.

How Gesturing Works

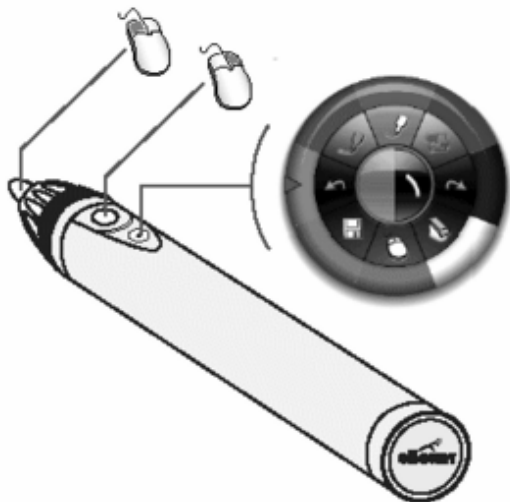

Using the Interactive Stylus

The diagram on the left demonstrates what each of the buttons on the Interactive Stylus are used for.

The bottom button (button furthest from the tip) is the Tool Palette button that is used to show and hide the Tool Palette.

The [Tool Palette button](#) is also used in gesturing.

How to Gesture

All gesture selections are performed using the Tool Palette button on the Interactive Stylus without touching the stylus to the projection surface. To gesture, hold the Interactive Stylus so that you can comfortably press the [Tool Palette button](#) with your finger.

Gestures can be performed anywhere on the screen area, regardless of the visibility or location of the Tool Palette.

A gesture begins when you press and hold the Tool Palette button and ends when the button is released. The invisible path of motion that is drawn between pressing and releasing the Tool Palette button determines the gesture selection.

Mapping a Gesture to a Tool

The Tool Palette contains 8 main tools in any environment.

One of eight tools can be selected at a time by gesturing a straight line from any point on the screen to the direction of the desired tool.

Mapping a Gesture to a Tool Property

A tool property is some defining characteristic of a tool. In the case of the [Pen Tool](#), the tool properties are pen color and line thickness.

Each tool might also have a property ring that can have from 4 to 8 different selections. For information on how to select a single property from a property ring, see [Select a Property](#).

It is only possible to use one property ring at a time. If you have just gestured to select a color but now want to select line thickness, you must change the property ring. See the following topics for information on how to change between the different property rings.

- [Switch to the Color Property Ring](#)
- [Switch to the Line Thickness Property Ring](#)
- [Switch to the Shapes Property Ring](#)

Select a Tool Property

Once you're in the desired tool property, you can make a selection by gesturing a straight line from any given point on the screen to the direction of the desired property and then back again to the starting point, all in one motion.

Switch To The Color Property Ring

To switch to the color property, begin a gesture from any given point on the screen and draw a straight line to the left, and then down - forming an approximate 90 degree corner.

Switch to the Line Thickness Property Ring

To switch to the thickness property, begin a gesture from any given point on the screen and draw a straight line to the right, and then down - forming an approximate 90 degree corner.

Switch to the Shapes Property Ring

The Shapes Tool is the only tool that has a shapes property.

To switch to the shapes property, begin a gesture from any given point on the screen and draw a straight line down, and then left OR right - forming an approximate 90 degree corner.

eBeam Inscribe Wireless Tablet

The eBeam Inscribe wireless tablet allows you to make annotations during presentations or while using Scrapbook using just the wireless pen and tablet and the [Tablet Toolbar](#). You have a number of options for configuring the behavior of the tablet and pen, including [Scrapbook Direct](#), [Standard Mouse Mode](#), [Absolute Mouse Mode](#) and [Relative Mouse Mode](#).

See the following topics:

- [Installing the Wireless Tablet](#)
- [Pairing the Tablet](#)
- [Absolute and Relative Mouse Mode](#)
- [Standard Mouse Mode](#)
- [Scrapbook Direct](#)
- [Using the Tablet Toolbar](#)

Installing the Wireless Tablet

Installing the wireless tablet is a simple two-step process.

1. Install the driver (included on the installation CD or found at <http://www.e-beam.com> under Downloads).
2. [Pair the tablet and your PC](#).

Pairing the Tablet

Pairing the tablet is the process of establishing communication between your PC and the tablet. You must do this before the tablet will function with your computer.

To pair the tablet

1. Plug the USB receiver, or key, into a USB port on your PC.
2. Turn on the wireless tablet by pressing its power button for at least three seconds.
3. Press the binding button on the back of the tablet and the binding button on the USB receiver simultaneously. Both the LCD display of the tablet and the blue LED of the USB receiver will blink.
4. Once the binding process has finished, notice that the LCD display of the tablet will show 000 to 005. If binding multiple tablets to a PC, each tablet will show a unique three digit number.

Note: You can pair up to five different tablets to your PC.

Absolute and Relative Mouse Mode

There are two ways to control the cursor when using the tablet--Absolute Mouse Mode and Relative Mouse Mode.

In Absolute Mouse Mode (the default setting), the area of the tablet is mapped directly to the screen area. The upper right tablet area equals the upper right corner of screen. When Scrapbook Direct is turned on and you are using Absolute Mouse Mode, the tablet surface maps directly to the Scrapbook page.

In Relative Mouse Mode, the pen and tablet behave the way a mouse typically works, or like a touch pad on a laptop. You can touch down, make a mark, lift up the pen, move it to the left or right, touch down again, and begin moving from the same spot on the screen. There is no direct or literal mapping of the tablet area to the screen workspace.

To select Absolute or Relative Mouse Mode

1. Select the Pen Pad icon in the Windows Taskbar menu.



The Pen Pad control window displays.

2. Under the About tab in the Tracking Mode area, select the Pen (Absolute) or Pen (Relative) radio button.
3. Select OK. The Pen is now in Absolute Mouse Mode.

Standard Mouse Mode

You can use the wireless tablet and pen in a standard manner to do the tasks you would typically perform with a mouse, such as locating files, selecting items, launching applications, and generally navigating your computer's operating system.

When using the tablet and pen in standard mouse mode, here is what you need to know about using the pen:

- Left-click - Pressing the tip of the stylus against the tablet is the equivalent of a left-click.
- Right-click - Pressing the button closest to the tip is the equivalent of a right-click.
- Double-click - Pressing the button farthest from the tip is the equivalent of a double-click.

Scrapbook Direct

With Scrapbook Direct turned on, the entire tablet working area is mapped directly to the current Scrapbook page. Since the pen and tablet cannot access anything outside of the current Scrapbook page when Scrapbook Direct is turned on, you can use the pen with the tablet toolbar along the top of the tablet to select different tools rather than changing tools with the eBeam Tool Palette.

To turn on Scrapbook Direct

1. Begin using the tablet in [standard mouse mode](#).
2. Launch Scrapbook.
3. Using the pen and tablet, press the Scrapbook Direct toolbar button on the far right end of the tablet toolbar. Scrapbook Direct is now on, and the tablet's writing surface is mapped directly to the current Scrapbook page.

Note: If Scrapbook is not open, the Scrapbook Direct toolbar button is disabled.

Using the tablet and pen with Scrapbook Direct turned on

When using the tablet and pen with Scrapbook Direct turned on:

- Pressing the tip of the stylus against the tablet is the equivalent of a left-click.
- The button closest to the tip is disabled.
- Pressing the button farthest from the tip toggles back and forth between showing and hiding the eBeam Tool Palette.

Using the Tablet Toolbar

Mouse on Desktop/Select in Scrapbook	In Scrapbook, use this button to choose the Select Tool. Outside of Scrapbook, use this button to select the Mouse from Desktop Tool.
Color Specific Pen Selection Buttons (red, green, blue, black)	Outside of Scrapbook, use these buttons to annotate the desktop, then save your desktop annotations in Scrapbook. If you are in Scrapbook, use these buttons to select a red, green, blue or black pen to use on a Scrapbook page.

Color Specific Highlighter Selection Buttons (yellow, green)	Outside of Scrapbook, use these buttons to annotate the desktop, then save your desktop annotations in Scrapbook. If you are in Scrapbook, use these buttons to select a yellow or green highlighter to use on a Scrapbook page.
Eraser	If you are not in Scrapbook, the eraser tool is disabled. If you are in Scrapbook, it selects the eraser tool.
Pen and Highlighter Thickness	If the Pen or Highlighter Tool is currently selected (on the desktop or in Scrapbook), these buttons change the thickness of the pen or highlighter. If the Pen or Highlighter Tool is not selected, these buttons are disabled.
Undo/Redo	Undo cancels the last change on a Scrapbook page. Redo allows you to redo the last undone change, provided you had previously used the Undo Tool.
Full Screen in Scrapbook	Press this button to either enter or exit full screen mode in Scrapbook. If you are not in Scrapbook the button is inactive. This function is not available when Scrapbook Direct is on.
Scrapbook Direct	Press this button to turn Scrapbook Direct on or off.

Document Camera

The eBeam Focus Document Camera (DocCam) takes still images or videos that you can use as backgrounds or objects on a Scrapbook page. Save your images in the Gallery for easy access, and weave them into your presentations. The images are stored as medium resolution jpeg files.

To launch eBeam Focus Viewer

The eBeam Focus DocCam works with Windows Vista and Windows XP, and does not require a driver.

1. Plug the DocCam into a USB 2.0 port on your computer.
2. Select the eBeam Focus Viewer button from the Scrapbook toolbar or from the [View](#) menu.

The eBeam Focus Viewer window opens, floating over the Scrapbook window. A live feed from the camera displays in the eBeam Focus Viewer window.

Note: If there is no DocCam connected, the following error message displays: "Your document camera could not be found. Check connection and try again."

Other Ways to Capture Images

- You can use the eBeam Focus Viewer button to launch any connected or embedded camera.
- You must load any required camera drivers and connect external cameras via USB.
- Caution: You cannot acquire images and video using twain drivers. Several commonly used cameras employ this method and will not launch from the eBeam Education Suite.

See the following topics:

- [Document Camera Folder](#)
- [Resizing the eBeam Focus Viewer Window](#)
- [Closing eBeam Focus Viewer](#)
- [Capturing Images and Video](#)
- [Alignment Grid](#)
- [Full Screen](#)
- [Meetings](#)

Document Camera Folder

The Document Camera folder displays in the Gallery once you have launched eBeam Focus Viewer with a DocCam connected to your computer. This is where the Gallery stores images and video clips captured from the DocCam.

Resizing the eBeam Focus Viewer Window

You can resize the eBeam Focus Viewer window by selecting and dragging the edges of the window. The Viewer window resizes with the movement of the mouse in real time. The DocCam Viewer window size does NOT affect capture resolution for images or videos.

Closing eBeam Focus Viewer







Select the red [X] in the upper right corner of the Viewer window. The DocCam Viewer window closes.

Capturing Images and Video

You can use the eBeam Focus DocCam to capture images and videos, then use them in your Scrapbook pages.

Document Camera Toolbar

Once you launch the Document Camera, you will see the Document Camera Toolbar. The following tools are available:

Add DocCam Image to Scrapbook as background		Adds the current still image in the DocCam to Scrapbook as a background.
Add DocCam Image to Scrapbook as object		Adds the current still image in the DocCam to Scrapbook as an object.
Add DocCam Image to the Gallery		Adds the current still image in the DocCam to Gallery in the Document Camera Folder.
Capture Video		Starts recording video with your Document Camera, and opens the Recorder Toolbar
Alignment Grid		Turns on/off the alignment grid. The alignment grid covers your current image in a 9 x 12 grid so you can align your image.
Recorder Toolbar		This tool is only available once you launch the recorder. The Recorder Toolbar contains the Record, Pause and Stop Buttons to record a video. Once you stop recording a Save As dialog box opens where you can enter the details to save your video.
Full Screen On		Expands the Document Camera Viewer Window to full screen. Turn full screen off by selecting the full screen off icon or right-click on the full screen image and select Full Screen Off.

Gallery

Adding Images to Scrapbook Pages

You can import an image from the Gallery into a Scrapbook page either as a [Scrapbook Element](#) or as a [Background Image](#). If you import an object as a Scrapbook element, then you can later move, rotate, resize, copy/paste and edit the object within the Scrapbook page. If you import an object as a background image, then the image is imported into the background of the selected Scrapbook page and cannot be edited the same way you can edit a Scrapbook element. In order to modify or delete a background, you must do so through [Background Settings](#).

Add an Image as a Scrapbook Element

1. Select a Scrapbook page.
2. Search for an image using the Gallery Folders, the [Favorites Folder\(s\)](#), the Encyclopædia Britannica Content folder or the [Flickr](#) search capability.
3. Once you have located the images you want to use, select them in the Preview Pane by pressing Shift+Select or Ctrl+Select while clicking on the images. With Shift+Select, you can select multiple adjacent images. With Ctrl+Select, you can select multiple non-adjacent images.
4. Use one of the following methods to add the image to the Scrapbook page:
 - With the image selected in the Preview Pane, select the Add as Object button from the Gallery Toolbar.
 - Drag-and-drop the object from the Preview Pane onto the Scrapbook page, Or
 - Double-click the object in the Preview Pane.

Scrapbook adds your selected images into the Scrapbook page as Scrapbook elements.

Note: With multiple images selected, the Add Object as Background option is not available since the background can consist of only one image.

Add an Image as a Scrapbook Page Background

1. Select a Scrapbook page.
2. Select an image using the Gallery Directory Tree and Preview Pane.
3. With the image selected in the Preview Pane, select the Add as Background button from the Gallery Toolbar.

The object is now shown on the Scrapbook page as a background. The background image has a default scale setting of Scale Proportionally. To change this setting, select the Page menu, then [Background Settings](#).

Favorites

The Favorites folder can help you quickly access the images that you use most often. A favorite is a short-cut to files in your Gallery. Deleting a favorite does not delete the actual file, it deletes only the reference to that file in your Favorites folder. You can also use sub-folders under the Favorites folder to organize your Gallery images.

- [Populating the Favorites Folder](#)
- [Using Favorites on Scrapbook Pages](#)
- [Working with Favorites Folders and Sub-Folders](#)

Populating the Favorites Folder

The Favorites folder is there to give you faster access to the images you use regularly. It does not come pre-populated with images.

To add a Gallery Object to the Favorites folder

1. Select a Gallery Object from the Preview Pane.
2. Drag and drop your selected Gallery Object into the Favorites folder, or right-click on your selected Gallery Object and choose Add to Favorites. A reference to the Gallery Object is saved to the Favorites root folder.

To remove a Gallery Object from Favorites folder

1. Select the Favorites folder or sub-folder that contains the object you want to remove.
2. From the Preview Pane, select the item you want to remove.
3. Right-click on your selected item and choose Delete Favorites, or press the Delete key on your keyboard. The reference to the Gallery Object is removed from the Favorites folder.

Working with Favorites Folders and Sub-Folders

The Favorites folder can help you track, organize and work with your favorite images. If you want to organize a larger set of favorite images, you may want to create a structure of sub-folders to name and use as you choose.

To add a sub-folder to the Favorites folder

1. Select the Favorites folder in the Gallery Directory Tree.
2. Select Add Folder from the Gallery Toolbar. The Add Folder dialogue box opens.
3. Enter a name for your new sub-folder in the Name field.
4. Click OK. Your new sub-folder appears under the Favorites folder.

To remove a folder from the Favorites folder

1. Select the folder that you want to remove.
2. Use one of the following methods to remove the folder:
 - Select Remove Folder from the Gallery Toolbar.
 - Right-click on the folder you want to remove, then click Remove Folder.

- Press the Delete key on your keyboard.
A dialogue will appear to confirm the removal.
- 3. Click Remove. The folder is removed from the Favorites folder.

Move Favorites from one Favorites folder to another

1. Navigate to the object in your Favorites folder that you want to move using the Preview Pane. Select the object.
2. Drag and drop the selected favorite into the new Favorites folder. The favorites object is removed from the original Favorites folder and placed into the new Folder.

Templates

If you have created a page that you want to use repeatedly, you can store it in the Templates folder. Starting out a new project with templates can save you time. You can begin with a template, then modify it as needed for each new project.

- [Populating the Templates Folder](#)
- [Working with Templates and Page Backgrounds](#)
- [Adding and Removing Links to Folders in the Templates Folder](#)

Populating the Templates Folder

To add a page to the Templates folder

Use one of the following methods for adding a page to the Templates folder:

1. Right-click directly on the Scrapbook page and select Add Page to Templates or select [Page](#) > Add Page to Templates. The Add Page to Templates Folder dialog window displays.
2. Enter a name for your new template page.
3. Click OK. A copy of the entire page and all its contents is saved as a template in the Templates folder.

To delete a template

1. Select the Templates folder.
2. From the Preview Pane, select the Template you want to delete.
3. Use one of the following methods to delete the template:
 - a) Select the Delete key on your keyboard or right-click the template in the Preview Pane and select Delete Templates. The Delete Template confirmation window displays.
 - b) Select Delete. The template no longer displays in the Preview Pane and is no longer associated with the Templates folder.

Working with Templates and Page Backgrounds

As you work with templates and page backgrounds, it is helpful to be aware of certain options you have. In the simplest case, you may have a blank Scrapbook page, and you want to start by adding a Template to your page that includes a background and some page objects.

In other cases, if you are working with a Scrapbook page that already has a background but you want to include page objects from a template that has a different background, you can add the page objects from the Template without replacing your current page background in Scrapbook.

You also have the option of replacing a page background with the background and objects from a template.

To add a Template Page to a Scrapbook Page

1. Select the Templates folder.

2. From the Preview Pane, select the template you want to add.
3. Select the Add as Background icon. The template background and objects are added to your current Scrapbook page.

If the Scrapbook page already contains a background, a dialogue box will open prompting you with the question: Would you like to replace the Current Background with the Template Background? Select Yes if you want to replace the current page background with the template background, and the background is replaced along with the template objects. Select No if you do not want to replace the current page background with the template background, and background is not replaced but the template objects are added.

You also have the option to add a template from the Preview Pane in the following ways:

- Right-click the template you want to use in the Preview Pane and select Add to Current Page or Add to New Page.
- Drag and drop the template page onto the current Scrapbook page.

Note: Master Page objects will be added as normal objects in the Scrapbook page.

Adding and Removing Links to Folders in the Templates Folder

To add a Link to a Folder in the Templates folder

1. Click the Templates Folder.
2. From the Gallery Toolbar, click the Add Link to Folder icon, or right-click on the Templates Folder and select Add Link to Folder . The Add Link to Folder dialog displays.
3. Enter a name and browse to the folder's location using the Browse button.
4. Click OK. The new linked folder displays under the Templates folder.

To remove a Link to a Folder from the Templates folder

1. Select the Templates sub-folder that you want to remove.
2. Right-click on the sub-folder and select Remove Link to Folder , or press the Delete key on your keyboard or select the Remove Link to Folder icon from the Gallery Toolbar. A confirmation dialogue window displays.
3. Click Remove. The sub-folder is removed from the Templates folder.

Flickr

We have integrated key features from Yahoo's photo sharing site [Flickr](#)(™) into the Gallery so that you can easily search for photos and integrate them into your Scrapbook pages. You can save images for later use by saving them in the [Favorites](#) folder.

- [Accessing Flickr](#)
- [Searching for Images](#)
- [Search History](#)

Accessing Flickr

Accessing Flickr through the Gallery is very simple. Select the Flickr folder, use search terms in the Flickr search field, and navigate through the Preview Pane to view the search results.

Note: To access Flickr through the Gallery, your computer must be connected to the Internet.

Searching for Images

Using the Flickr search field, you can quickly search for and select among millions of images from Flickr.com.

To search for images in Flickr

1. Enter a search term in the Flickr search field. 
2. Select the magnifying glass icon or press Enter to initiate your search. Images relating to your search term will appear as thumbnails in the Preview Pane.

Search History

For your convenience, the Flickr search field saves your search history. You can clear the search history whenever you like.

To show the search history

Click the down arrow to the right of the search field. The search history displays in the drop-down list.

To clear the search history

1. Click the down arrow to the right of the magnifying glass icon.
2. Select Clear Recent Searches. The search history is now cleared.

Encyclopædia Britannica

We have integrated key features from Encyclopædia Britannica into the Gallery giving you access to a wide range of educational content and online resources while navigating Scrapbook. Search for information to incorporate into your presentations or save images in your Scrapbook meeting file. All images that you save will be stored in the [Encyclopædia Britannica Content folder](#) for later use.

Note: You must have the Encyclopædia Britannica software installed or be logged into your existing Encyclopædia Britannica account before you can access all of the resources available in the Encyclopædia Britannica directory. If you are already a registered Britannica user, clicking the directory link from the Gallery will give you the opportunity to log into your account. If you are not a registered user or don't have the Britannica software installed, you will have the opportunity to start a trial session or sign up for an Encyclopædia Britannica subscription once you click the directory link from the Gallery. You must be online in order to log into your account, register for a trial session or sign up for Encyclopædia Britannica subscription.

- [Accessing Encyclopædia Britannica](#)
- [Encyclopædia Britannica Content Folder](#)

Accessing Encyclopædia Britannica

In order to access Encyclopædia Britannica from the Gallery, you must first install the Encyclopædia Britannica software using the installation CD that came in your box. Once the software is installed, click the Encyclopædia Britannica directory in the Gallery directory tree.

A separate window will open floating over your Scrapbook page, prompting you to choose which library you want to start browsing. Make your selection and start browsing.

Note: Once you launch your Encyclopædia Britannica software, a new directory called Encyclopædia Britannica Content will appear in the Gallery directory tree.

Encyclopædia Britannica Content Folder

For your convenience, you can save any images you find while browsing Encyclopædia Britannica in your Gallery for later use. These images will be stored in the Encyclopædia Britannica Content folder in your Gallery directory tree.

Save images to your Encyclopædia Britannica Content Folder

1. Search for an image in your Encyclopædia Britannica software.
2. When you have found an image you want to keep for later use, press the Save button or right-click the image and select Save Image As.
3. Name the file in the Save dialog box that appears and click the Save button.

Note: If you try to save content other than an image, you will only be given the option to Save As (instead of Save Image As). Click the image you want to save until you are given

the option to Save Image As. If you save content other than an image, you will not be able to access it from the Gallery. See [Preview Pane](#) for file types that are compatible with the Gallery.

Access images in your Encyclopædia Britannica Content Folder

1. Click on the Encyclopædia Britannica Content folder in your Gallery directory tree. All images that you have added will be displayed in the Preview Pane.
2. Select the image you would like to use in the Preview Pane.

See [Adding Images to Scrapbook Pages](#) for information on how to incorporate these images into your presentation.

Shared Meetings

What is a Shared Meeting?

A Shared Scrapbook Meeting is a meeting that is broadcast over your local intranet or the Internet.

At one location, the meeting coordinator/host uses the interactive system (software and hardware) to host or broadcast the meeting over the network (see [Hosting/Sharing a Meeting](#)). Remote participants use the interactive software or a Web browser to log into the meeting (see [Join a Meeting](#)).

The meeting is held in real time, which means that remote participants see the notes and annotations as they are created.

If the meeting coordinator allows, participants can annotate meeting pages, highlight important points, and add notes that can be seen by all other participants as well as the coordinator.

To allow remote participants (located outside of your local network firewall) to access your shared meeting, the meeting server must be located on the Internet. Luidia currently hosts a meeting server that may be used by any eBeam-enabled interactive system user.

Hosting/Sharing a Meeting

The following explains how to host/share a meeting over your local intranet or the Internet.

When sharing a meeting, be aware of the following items.

- While Scrapbook v2.2 can open files created by previous versions of Scrapbook (v2.1 and earlier), previous versions of Scrapbook cannot open v2.2 files. During shared meetings, previous versions of Scrapbook do not support (will not display) text boxes created in Scrapbook v2.2. Scrapbook v2.2 will display (but cannot edit) text boxes created by previous versions of Scrapbook.

If hosting a shared meeting using Scrapbook v2.2, we recommend that you select the Deny access to remote participants with mismatched software versions checkbox from the Share Meeting dialog box.

- If you share the meeting on your local intranet, only people within your intranet can access the meeting. If you share your meeting over the Internet (using an eBeam server), participants from any Internet location can access your meeting.
- To share a meeting an interactive receiver or software activation must be detected. Also, if there is any possibility that your network uses a proxy server, see [Proxy Server Setup](#).
- You can host one shared meeting at any time.

See:

- [Hosting A Shared Meeting](#)
- [Leaving A Shared Meeting](#)

For meeting host specific tools, see Meeting Host Tools found in the [Participants](#) window.

Hosting a Shared Meeting

1. Choose Meetings > Share Meeting, or select the Share Meeting button from the Scrapbook Toolbar to open the Share Meeting dialog.
2. Under Meeting Information, enter the following:

Meeting Name	The meeting name is the name shown in the Meeting dialog box. The meeting name is saved as the default name for subsequent meetings, until you change it. The meeting name can be up to 20 characters.
My Name	The name displayed in the Participants View. See Participants
Notes	Any notes/comment you would like to include.
Publish Meeting Name	Select Publish Meeting Name if you want the name of the meeting to be visible to network users who are attempting to join a meeting using either the Join Meeting (Joining a Meeting for more information) dialog box, or the Meetings web page located at www.e-beam.com . If you do not publish the name, guests will need to know the full meeting name beforehand manually type it into the Join Meeting dialog box.
Password/Confirm/Use Password	If a password is required, check the Use Password checkbox and type the same password into both the Password and Confirm text boxes. The password must be at least 6 characters, and can be up to 20 characters.
Send Meeting Invitation	Meeting invitations are e-mail invitations that are sent out using your standard e-mail client. Send Meeting Invitation is checked, the Send Invitation dialog box opens once you select the Share Meeting button. See Sending an Invitation for more information.

Archive Meeting on the Server	An archived meeting allows you to search for, view, download, edit and/or delete your archive meeting (based on the archive privileges you select). Archive Meeting on the Server is checked, the Archive Meeting dialog opens after you select the Share Meeting button. See Archive a Meeting for more information.
Synchronize Participants Immediately	Causes remote participants to be synchronized from the start of the meeting. Synchronize is by default. See Participants
Deny access to remote participants with mismatched software versions	The version of software you are using is not fully compatible with previous versions. During a shared meeting, participants running previous versions may not be able to see imported image files and will not be able to see when annotation or image elements are moved, rotated, res etc. Selecting Deny access to remote participants with mismatched software versions will only allow participants using the same software version or later to join your meeting.

Notes:

- o While the Archive Meeting dialog appears after selecting the Share Meeting button, your selected archive parameters are not saved to the server until you select the End Meeting button. However, meeting data is cached on the server in case the meeting unexpectedly quits.
 - o During your meeting, you may change your meeting parameters at any time by choosing Meeting > Archive Meeting.
3. Under Server Information , select the server that will host the meeting.
The pull-down menu lists the default server and any other servers you have previously added to your server list.
Note: If you wish to host the meeting from your computer, select Use my PC to Host this Meeting and then type in a port number. For most occasions, the default port value of 80 is best.
 4. Notify guests of the meeting name, meeting time and password, if required. See Sending an Invitation for more information.
 5. Select Share.

Your shared meeting is now available on the network using the specified meeting server.

Leaving A Shared Meeting

To leave a shared meeting at any time:

1. Select the Share/End Meeting button from the Scrapbook Toolbar.
2. Choose Meetings > End Meeting

Important Note: When the meeting host ends a shared meeting, all participants are disconnected from the meeting. As the meeting host, make sure the meeting is completely over before attempting to close the meeting.

Join a Meeting

Using Scrapbook to Join a Meeting

1. Open Scrapbook from:
 - the eBeam Tool Palette, or
 - the [eBeam Education Taskbar menu](#) , or
 - the Scrapbook menu option found in the Windows Start bar.
2. Choose Join Meeting from the Scrapbook Toolbar .
3. In the Join Meeting dialog box, select the meeting server, enter your name and select a meeting name from the Meeting list.

The Meeting list shows active meetings whose names have been published.

If the pull-down menu does not include the meeting server you want, you can manually type the server name. You can also add a server to your server list so that you can quickly select it on another occasion.

4. Select Refresh to update the list of published meetings.
 - If the meeting appears with a Lock icon, enter the password.
 - If the meeting is not listed, enter the meeting name and a password if required.
5. Select Join.

To leave a meeting, choose Meetings > Leave Meeting From, or select the Leave Meeting button from the Scrapbook Toolbar.

Notes:

- When the meeting host ends a shared meeting, all participants are disconnected from the meeting. Once disconnected, participants can continue to print, save, annotate and modify their Scrapbook record of the meeting.

Sending an Invitation

You can invite others to a [shared meeting](#) by sending an e-mail invitation that contains a link to the meeting. In order to send email invitations:

1. In the Share Meeting dialog, check the Send Meeting Invitation checkbox or make sure you are sharing a meeting and choose Meetings > Send Invitation. See [Sharing a Meeting](#) for more information.
2. Select the language to be used for the e-mail invitation and then select Continue. At this point, your e-mail program might ask you to select the e-mail profile to be used.
3. A new e-mail with the Meeting Request information opens. Enter the e-mail addresses of the recipients in the To: field.
4. Select Send.

The e-mail invitation includes a link for downloading the latest software and links to enable the user to join the meeting via their Web browser or the software.

Note: Remote participants cannot send out invitations.

Accepting an Email Invitation

You can accept an e-mail invitation in one of the following ways:

- Double click the http: link in the email invitation to automatically launch the meeting in your browser or copy and paste the http: link into your web browser. When the meeting login screen appears, select the Join button.
- In Scrapbook, select the Join button and manually fill in all of the meeting fields using information provided by the invitation.

See [Sending an Invitation](#) for more information.

Archive a Meeting

Archive Meeting allows you to archive your Scrapbook meeting file on an eBeam server. The meeting can later be retrieved to be viewed, edited, printed or shared.

There are two areas in Scrapbook where you can select to archive a meeting.

- While hosting a shared meeting, go to the Share Meeting dialog and select the Archive Meeting on the Server checkbox to have the Archive Meeting Screen open. See [Hosting/Sharing a Meeting](#) for more information about sharing a meeting.
- After creating/completing a meeting: you have the choice of archiving that meeting (to the server) for viewing and/or downloading by other users or only for those users with password-access.

To select this option:

- Save the meeting
- Choose File > Archive Meeting
- Select the server to archive the meeting on and select Continue. The [Archive Meeting Screen](#) will open next. Note: It is not possible to Archive a Meeting when you use the Use my PC to host this meeting option.

Archive Meeting Screen

Use the Archive Meeting screen to define meeting information, security access requirements, the file access expiration period, and review the Conditions of Use.

Meeting Information Section

- Meeting Name: Retain the current saved meeting name or create a new name for the archived meeting.
- Publish Meeting Name checkbox: Check to have archived meeting published (available for searching)

Access Security Section

- Password access: Check the box to require a specified password before your archived meeting can be retrieved. If checked, enter a password, and then re-enter it for confirmation.
- Security Code: Check the box to require a specified security code before a Scrapbook user can edit or delete the archived meeting file. Note: if the box is checked, but no security code is specified, the defined password is automatically used.

Access Period Section

- The text appearing in this section displays the current expiration period for storing and accessing the archived meeting file. After this time, the file is deleted from the server.

- Select the Change button to edit the current criteria via the Access Period Screen, as described below.

Access Period Screen

- Meeting Storage: Choose the default, or select a specific date.
- Meeting File Availability: Define the duration the archived meeting will be available for other Scrapbook users to view and/or download.
 - Always (until deleted): Available until the same defined final date as meeting storage date.
 - During Specific Time Period: Specify exact days and times for starting and ending availability. Note: End Date may also be until the file is deleted from the server (see final meeting storage date) by checking the Until Deleted box.
- Summary Section: Text appearing in this section displays the updated expiration period for storing and accessing the archived meeting file. After this time, the file is deleted from the server.

Archive Meeting Buttons

- Conditions of Use: Select this button to review the conditions of use for the Luidia product.
- Help: Select to display the context-sensitive help for this screen.
- Archive: When all your selections are complete, select the Archive button.
- Cancel: Select to cancel your archive request.

Retrieve a Meeting

Retrieve a meeting by choosing the File > Retrieve Meeting menu selection to open the Retrieve Archived Meeting screen. You may search and retrieve archived meetings for viewing or downloading at any time, though some meetings may require password-access.

The following topics describe the elements and activities available to you via the Retrieve Archived Meeting screen.

- [Recent Archived Meetings Screen](#)
- [Edit Archived Meeting Screen](#)
- [By Meeting Name Screen](#)
- [Full Search Screen](#)

Recent Archived Meetings Screen

Use the Recent Archived Meetings screen to list, edit, delete, and/or retrieve previously archived meetings. Note: editing and deleting a meeting may require a security code. If required, you will be prompted.

- Server: Use the selector to choose the eBeam server where the archived meeting resides. If necessary, you may also select the Browser button and manually search for the server location.
- Time-span selector: Choose between displaying today's meetings through all meetings archived to the eBeam server within the last 90 days.
- Meeting List: Shows a list of meetings archived on the server and each meeting's size, owner, when it was archived and when it expires (date archived meeting is no longer available to retrieving, editing, etc.).
- Refresh Button: Use at any time to refresh the current meeting list, including any recent meetings archived by other users.
- Retrieve Button: After highlighting an archived meeting, select the Retrieve button to retrieve that meeting.
- Edit Button: After highlighting an archived meeting, if the Edit button is available, you can edit the archive parameters for that meeting.
- Delete Button: After highlighting an archived meeting, if the Delete button is available, you can delete that meeting.
- Close Button: Select to close the screen.

Edit Archived Meeting Screen

Use the Edit Archive Meeting screen to edit meeting information, security access requirements, and the file access expiration period.

- Meeting Name: Retain or change the current archived meeting name.
- Publish Meeting Name checkbox: Check to have archived meeting name published (available for searching).
- Password Access: Check the box to require a specified password before a user can retrieve your archived meeting. If checked, enter a password, and then re-enter it for

confirmation.

- Security Code: Check this box (default) to require a specified security code before a user can edit or delete the archived meeting file. Note: if the box is checked, but no security code is specified, the defined password is automatically used.

Access Period Section

- Meeting Storage: Choose the default or select a specific date.
- Meeting File Availability: Define the duration the archived meeting will be available for other users to download. Select one of the following.
 - Always (until deleted): Available until same final date as defined file storage date.
 - During Specific Time Period: Specify exact days and times for starting and ending availability. Note: End Date may also be until the file is deleted from the server by checking the Until Deleted checkbox.
- Summary section: Text appearing in this section displays the updated expiration period for storing and accessing the archived meeting file. After this time, the file is deleted from the server.

By Meeting Name Screen

Use this screen to retrieve a specifically defined archived meeting.

- Server: Use the selector to choose the eBeam server where the archived meeting resides. If necessary, you may also select the Browser button and manually search for the server location.
- Meeting Name: Enter the exact name of the archived meeting. Note: this entry is case-sensitive.
- Password: If required, enter the case-sensitive password for the desired archived meeting.
- Retrieve Button: Select the Retrieve button to retrieve that meeting. Note: a dialog box appears allowing you to open the meeting, download the meeting to a specified location, or cancel your request.
- Retrieve Button: After entering the exact name of the archived meeting, select the Retrieve button to retrieve the meeting. Note: a dialog box appears allowing you to open the meeting, download the meeting to a specified location, or cancel your request.
- Edit Button: After entering the exact name of the archived meeting, if the Edit button is available you can edit the archive parameters for that meeting. Note: you may be prompted for a security code to edit the meeting.
- Delete Button: After entering the exact name of the archived meeting, if the Delete button is available you can delete that meeting. Note: a password and a security code may be required for deletion. A prompt will appear asking you to confirm your deletion request.
- Close Button: Select to close the screen.

Full Search Screen

Use the Full Search screen to locate one or more archived meetings by meeting name, owner

name, and/or date and time.

- Server: Use the selector to choose the eBeam server where the archived meeting resides. If necessary, you may also select the Browser button and manually search for the server location.

Search Criteria Options

You can select one or more of the search options described below.

- Search by Meeting Name: Searches by meeting name. Select the checkbox to specify this search method. The meeting name may be case-sensitive. To search for a meeting by name, enter the name exactly, partially, or begin with the first letters for the search.
- Search by Owner Name: Searches by the name of the owner workstation of the archived meeting. Select the checkbox to specify this search method. The owner name may be case-sensitive. To search for a meeting by owner name, enter the name exactly, partially, or begin with the first letters for the search.
- Case-sensitive Search checkbox: Check to have Meeting and/or Owner Name entry search be case-sensitive.
- Exact Name: Select to have search find archived meetings that exactly match the Meeting and/or Owner Name entry.
- Name Starts with: Select to have search find meetings that start with the Meeting and/or Owner Name entry.
- Name Contains: Select to have search find meetings that contain some portion of the Meeting and/or Owner Name entry.
- Search by Archiving Date/Time: Use this section to define date/time ranges for searching archived meetings.
- From Date: Select the beginning date for the meetings you want to retrieve. You can also use the calendar icon to automatically enter a date.
- To Date: Select the ending date for the meetings you want to retrieve. You can also use the calendar icon to automatically enter a date.
- Search: When you have completed all your selections, select Search. The results are displayed in the Search Results section.
- Retrieve: After highlighting an archived meeting, select the Retrieve button to retrieve that meeting. Note: a dialog box appears allowing you to open the meeting, download the meeting to a specified location, or cancel your request.
- Edit: After highlighting an archived meeting, if the Edit button is available you can edit the archive parameters for that meeting. Note: you may be prompted for a security code to edit the meeting.
- Delete: After highlighting an archived meeting, if the Delete button is available you can delete that meeting. Note: a password and a security code may be required for deletion. A prompt will appear asking you to confirm your deletion request.
- Close: Select to close the screen.

Participants

The Participants window allows you to see information about every participant logged into a shared meeting and to [Chat](#) with connected participants. To open the Participants window while participating in a shared meeting:

- Choose [View](#) > Participants, or
- Press Ctrl+4, or
- Select the Participants button from the Scrapbook Toolbar.

The Participants window lists the following information for participants logged into the meeting through Scrapbook or Capture. Note: Participants logged in through the web viewer are not shown in the Participants window.



Chat	The Chat section can be shown or hidden by clicking on the arrow. Chat allows meeting participants to send text messages to one another while logged into the shared meeting. See Chat for more information.
Participant Name	The name of the participant as entered in the My Name text box in the Join Meeting dialog box. See Join a Meeting for more information.
Interactive/View Only	Write permission is displayed by an icon. When the participant has permission to annotate the meeting, a pen icon is displayed. When the participant does not have permission to annotate the meeting, the pen icon is displayed with a line through it.
Connected At	Displays the time the participant connected to the meeting.
IP Address	Displays the participant's IP Address.
Notes	Displays any notes entered into the Notes field in either the Share Meeting or Join Meeting dialog box. See Join a Meeting for more information.

You can find additional participant information by selecting a participant name and either pressing the Tool Palette button on the Interactive Stylus or right-clicking the name with your mouse and choosing Participant Information from the displayed menu.

Meeting Host Tools

The following tools are available only to the meeting host (the person who set up the shared meeting).

Set View Only/ Interactive		<p>The meeting host can set a participant status to View Only or Interactive. An Interactive participant is able to annotate the page. A View only participant is only able to view the page, but not able to annotate. To set a participant status to View Only or Interactive, select the participant in the Participants window, and then select the Set View Only/Interactive button.</p> <p>You can select multiple participants by holding down the Ctrl button on your keyboard and clicking participant names.</p> <p>The Set View option is also available when you select a participant name and either press the Tool Palette button on the Interactive Stylus or right-click the name with your mouse then choose the Allow Annotations option.</p>
-------------------------------	---	---

Dismiss Participant(s)		<p>Dismiss Participant allows the meeting host to disconnect a participant from the meeting. To dismiss a participant from the meeting, select the participant in the Participants window, and then select the Dismiss Participant button.</p> <p>The Dismiss Participant option is also available when you select a participant name and either press Button A on the Interactive Stylus or right-click the name with your mouse then choose the Dismiss Participant option.</p>
Synchronize Participants		<p>If the meeting host has selected Synchronize Participants remote participants are only able to view the page that the host is viewing. However, remote participants are still able to annotate the page. Synchronize is on by default.</p>

Chat

The Chat window allows participants in a shared meeting to send text messages to one another in the course of the meeting.

Messages can be sent to anyone listed in the Participants List, by typing a text message into the New Message text box, and then clicking one of the buttons listed next to Send To.

The following controls are contained in the Chat window:

Control	Description
New Message	Creates a new text message. Type the new outgoing text message into the New Message text box, and then select All or Selected Participants to send the message.
Show Addressee	Lists the name(s) of email recipients. Show Addressee has been checked, once a text message has been sent, the participant(s) that the message was sent to are listed next to the message. Note: For incoming messages, the sender's name is always listed next to the message.
Show Time	Lists the time of email messages. Show Time has been checked, once a text message has been sent, the time the message was sent to is listed next to the message.
Color Coded	If Color Coded has been checked, then incoming/outgoing text messages are color coded in the Chat window. The color codes are defined as: <ul style="list-style-type: none"> • Black - Incoming text message. • Blue - Outgoing text message. • Red - Priority text message. Incoming and outgoing.
Priority Message	Color codes a high-priority message. If Priority Message has been checked, the outgoing/incoming message is displayed in red. Note: If Color Coded is not checked, the message is displayed in black.
All	Sends the text message in the New Message text box to all connected participants. This button is disabled until a text message has been typed into the New Message text box.
Selected Participants	Sends the text message in the New Message text box to all selected participants in the Participants List. Multiple participants can be selected/deselected by holding down the Shift or Control button. This button is disabled until a text message has been typed into the New Message text box.
Clear	Clears all previously sent/received text messages from the Chat window. However, does not clear any text in the New Message text box.

To show/hide the Chat window, click the green arrow located next to the Chat title.