

## Installation and Assembly Manual:

Ceiling Mount for NP-PE506WL, NP-PE506UL, NP-PE456USL, NP-MC453X, NP-MC423W, NP-ME453X, NP-ME423W, NP-ME403U, NP-P474W, NP-P474U, NP-P554W, NP-P554U Projectors

Model: MP300CM

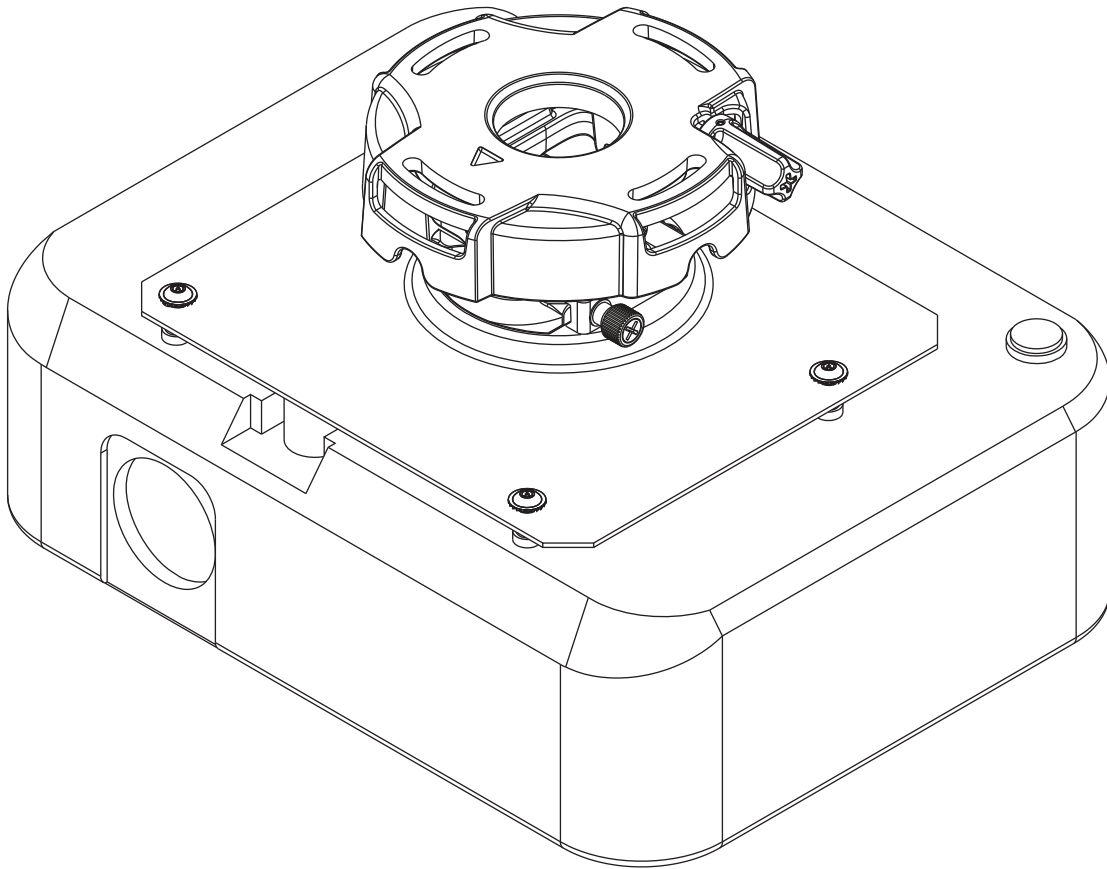

### Features:

- ImageLock™ alignment prevents picture sag or drift
- Wrench access slot for easier flush mount installations
- Exclusive aluminum track quick release



Max UL Load Capacity: 50 lb (22.7 kg)



**NOTE:** Read entire instruction sheet before you start installation and assembly.

## ⚠ WARNING

- Do not begin to install your Peerless product until you have read and understood the instructions and warnings contained in this Installation Sheet. If you have any questions regarding any of the instructions or warnings, please call Peerless customer care at 1-800-865-2112.
- This product should only be installed by someone of good mechanical aptitude, has experience with basic building construction, and fully understands these instructions.
- Make sure that the supporting surface will safely support the combined load of the equipment and all attached hardware and components.
- Never exceed the Maximum UL Load Capacity. See page 1.
- If mounting to wood joist ceilings, make sure that mounting screws are anchored into the center of the joist. Use of an "edge to edge" stud finder is highly recommended.
- Always use an assistant or mechanical lifting equipment to safely lift and position equipment.
- Tighten screws firmly, but do not overtighten. Overtightening can damage the items, greatly reducing their holding power.
- This product is intended for indoor use only. Use of this product outdoors could lead to product failure and personal injury.
- This product was designed and intended to be mounted to the following supporting surfaces checked below with the hardware included in this product as specified in the installation sheet. To mount this product to an alternative supporting surface, contact Peerless customer care at 1-800-865-2112.
- This product was designed to be installed on the following ceiling construction only;

### CEILING CONSTRUCTION

### ADDITIONAL HARDWARE REQUIRED

<input checked="" type="checkbox"/> Wood Stud	None
<input checked="" type="checkbox"/> Wood Joist	None
<input checked="" type="checkbox"/> Solid Concrete	None
<input type="checkbox"/> Cinder Block	Contact Customer Service
<input type="checkbox"/> Brick	Contact Customer Service
Other or unsure?	Contact Customer Service

## Tools Needed for Assembly

- stud finder ("edge to edge" stud finder is recommended)
- phillips screwdriver
- drill
- 5/16" bit for concrete surface
- 5/32" bit for wood studs
- level

## Table of Contents

Parts List.....	3
Installation to Extension Columns / Ceiling Plate .....	4
Installation to Wood Joist Ceilings.....	5
Installation to Concrete Ceilings.....	6
Attaching Adapter Plate to Projector.....	7
Attaching Adapter Plate to Projector Mount.....	8
Projector Alignment .....	9

Before you start check the parts list to insure all of the parts shown are included.

<b>Parts List</b>		Qty.	Part #
Description			
<b>A</b> projector mount assembly		1	054-2171
<b>B</b> 4 mm security allen wrench		1	560-9646
<b>C</b> #10-32 x 3/8" serrated washer head socket pin screw		2	520-2151
<b>D</b> #10-32 x 1/4" socket pin screw		1	520-2196
<b>E</b> flat washer		2	540-1078
<b>F</b> #14 x 2.5 phillips hex head wood screw		2	5S1-015-C04
<b>G</b> concrete anchor		2	590-0320
<b>AA</b> adapter plate		1	055-2985
<b>BB</b> M4 x 16 mm serrated socket pin screw		4	510-2087
<b>CC</b> retaining spacer		4	590-2009
<b>DD</b> 2 mm allen wrench		1	560-1097
<b>EE</b> connection block		1	580-4065

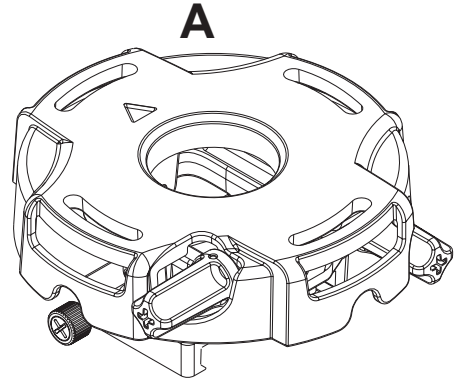

**NOTE:** Actual parts may appear slightly different than illustrated.

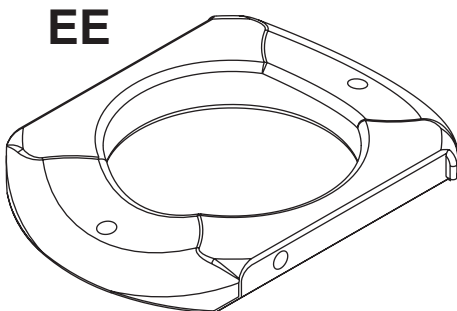
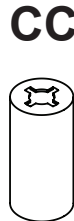
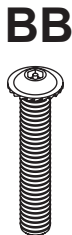
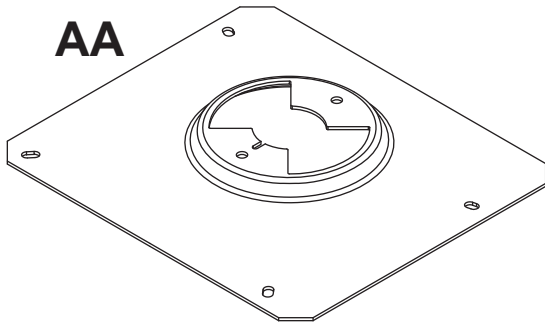
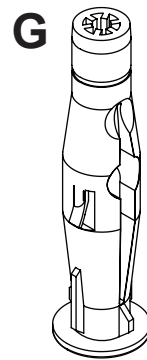
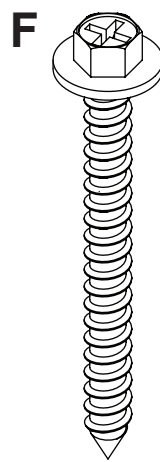
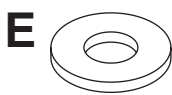
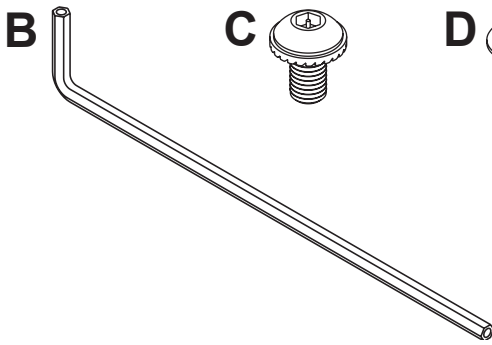

## Installation to Extension Column / Ceiling Plate

**1** **NOTE:** Refer to accompanying instructions with ceiling plates (sold separately) for installing these models to ceiling.

Screw projector mount assembly (A) onto extension column as shown in **figure 1.1**. Tighten swivel stop screw against extension column, flush mount tube or reducer using 4 mm security allen wrench (B) as shown in **figure 1.2**.

**NOTE:** Swivel stop screw is used to jam against threads of extension column, flush mount tube or reducer to prevent any excess movement of projector mount assembly (A). Do not overtighten screw; overtightening screw will damage threads making it difficult to separate products.

**Skip to step 4.**

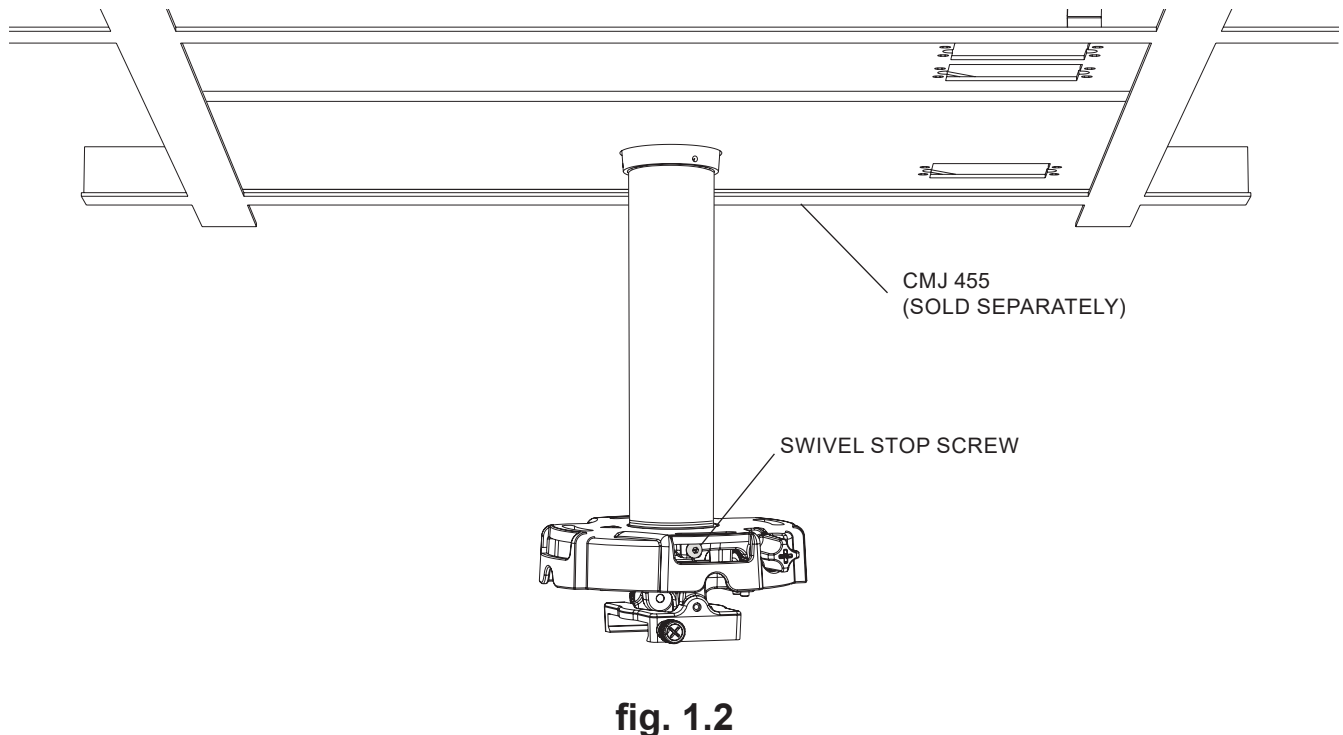
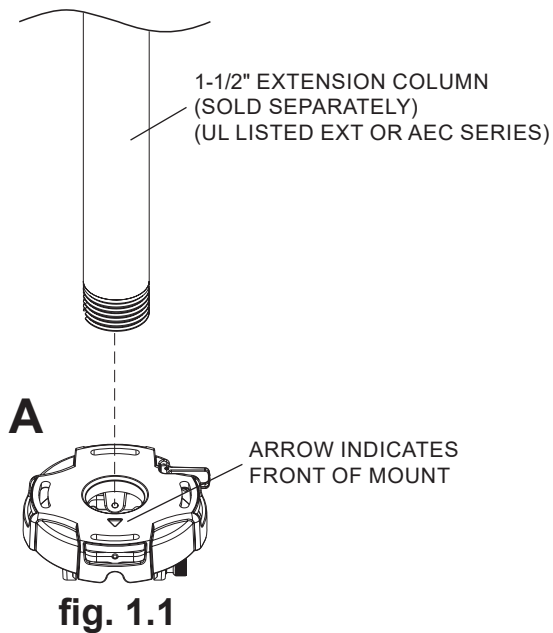

## Installation To Wood Joist Ceilings

### ⚠ WARNING

- Installer must verify that the supporting surface will safely support the combined load of the equipment and all attached hardware and components.
- Tighten wood screws so that projector mount assembly is firmly attached, but do not overtighten. Overtightening can damage the screws, greatly reducing their holding power.
- Never tighten in excess of 80 in. • lb (9 N.M.).
- Make sure that mounting screws are anchored into the center of the stud. The use of an "edge to edge" stud finder is highly recommended.
- When installing Peerless ceiling mounts on a wood joist/beam covered with gypsum board (drywall), verify that the joists or beams are a minimum of 2" x 4" nominal size. Do not install over gypsum board thicker than 5/8".

**2** Place projector mount assembly (**A**) on ceiling as a template and mark the center of the two mounting holes. Make sure that the mounting holes are in the center of the wood joist. Drill two 5/32" (4mm) dia. holes to a minimum depth of 2.5" (64mm). Attach projector mount assembly (**A**) with two #14 x 2.5" wood screws (**F**) and two flat washers (**E**) as shown in **figure 2.1** or **figure 2.2** depending on joist orientation.

**NOTE:** Mounting slots on projector mount assembly allow for 30° (±15°) of swivel adjustment before fully securing wood screws.

Tighten wood screws (**F**) using 3/8" (10mm) socket wrench, phillips screwdriver or 10mm open end wrench until projector mount assembly (**A**) is firmly attached.

**Skip to step 4.**

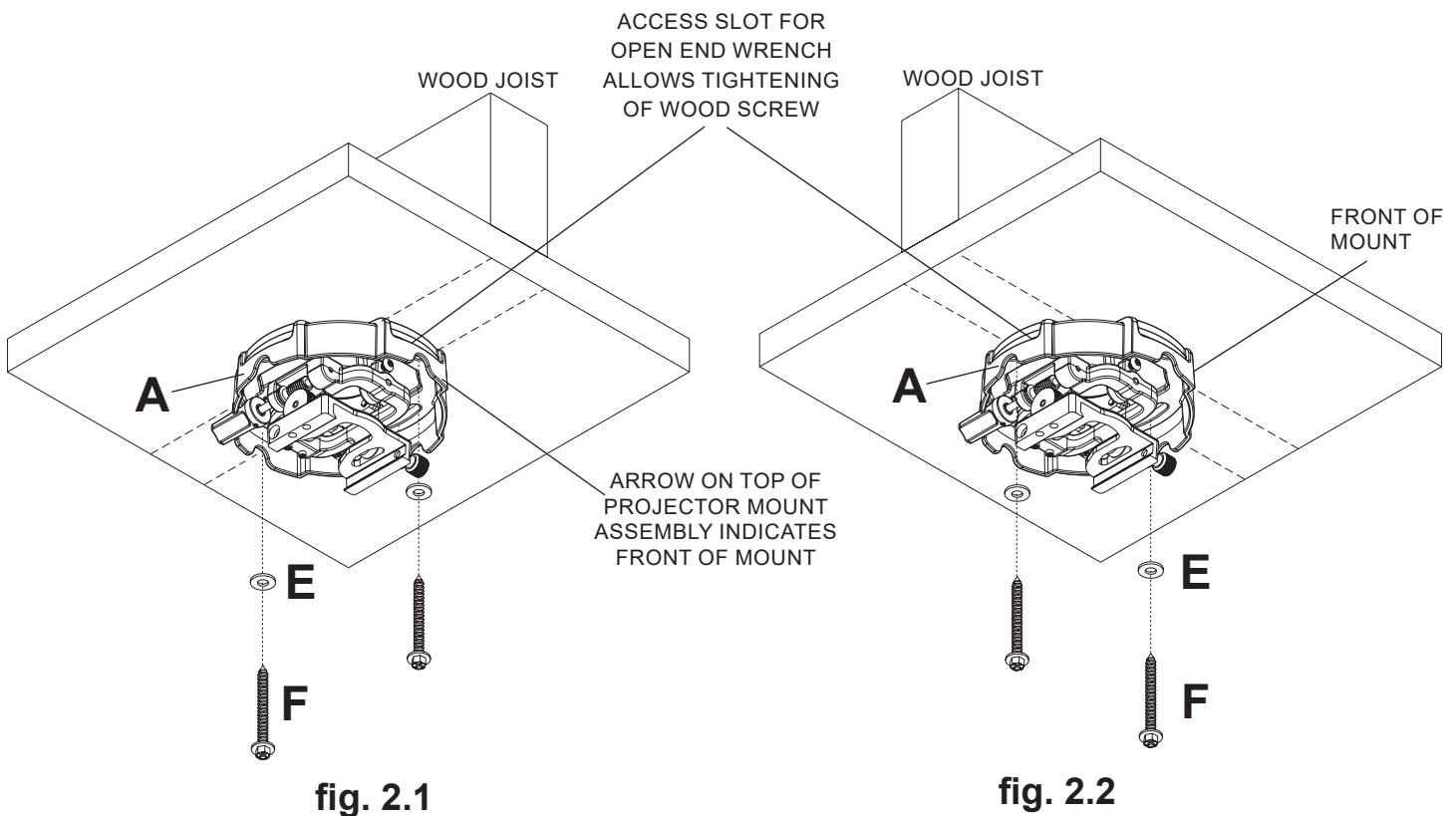

## Installation to Concrete Ceilings

### ⚠ WARNING

- When installing Peerless ceiling mounts on a concrete ceiling, the ceiling must be at least 8" thick with a minimum compressive strength of 2000 psi. Never attach concrete expansion anchors to concrete covered with plaster, drywall, or other finishing material.
- Make sure that the supporting surface will safely support the combined load of the equipment and all attached hardware and components.

- 3** Place projector mount assembly (A) on ceiling as a template and mark the center of the two mounting holes. Drill two 5/16" (8mm) dia. holes to a minimum depth of 2-1/2" (64mm). Attach projector mount assembly (A) using two concrete anchors (G), two flat washers (E), and two #14 x 2-1/2" wood screws (F) as shown in **figure 3.1**.

**NOTE:** Mounting slots on projector mount assembly allow for 30° ( $\pm 15^\circ$ ) of swivel adjustment before fully securing wood screws.

Tighten wood screws (F) using 3/8" (10mm) socket or open end wrench or phillips screwdriver until projector mount assembly (A) is firmly attached.

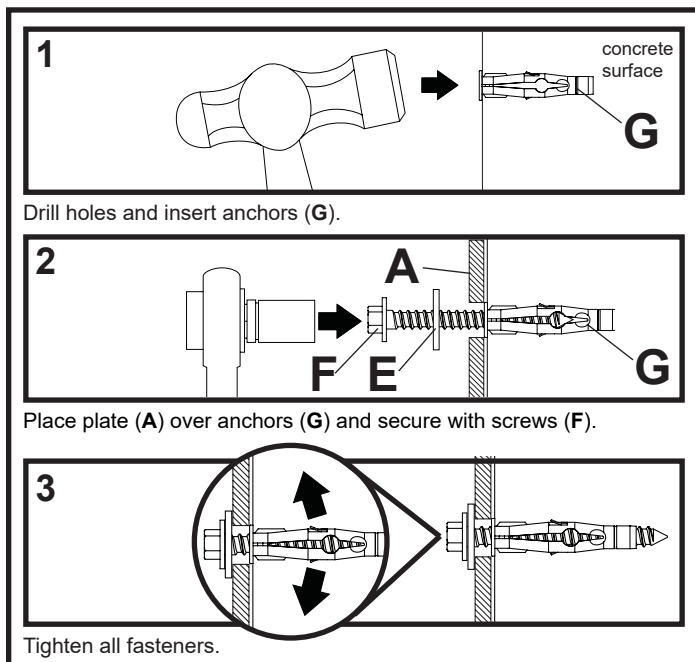

### ⚠ WARNING

- Tighten wood screws firmly, but do not overtighten. Overtightening can damage the screws, greatly reducing their holding power.
- Never tighten in excess of 80 in • lb (9 N.M.).

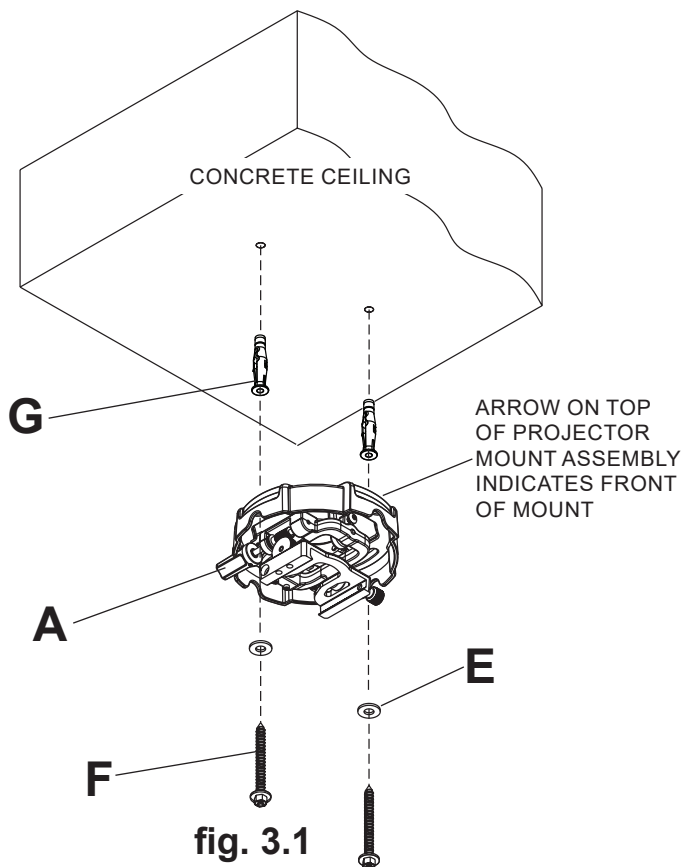

## Attaching Adapter Plate to Projector

- 4** Align shoulder on connection block (**EE**) opposite notch in adapter plate (**AA**). Attach adapter plate (**AA**) to connection block (**EE**) using two #10-32 x 3/8" serrated washer head socket pin screws (**C**) as shown in figure 4.1. Tighten screws using 4 mm allen wrench (**B**).

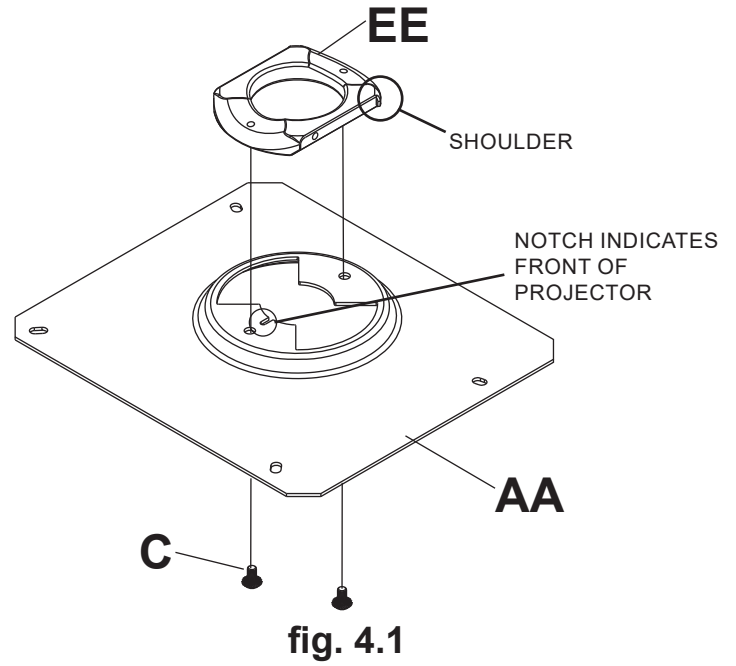

- 5** Flip projector upside down and attach adapter plate (**AA**) using four serrated socket pin screws (**BB**) and retaining spacers (**CC**) as shown below. Tighten using 4 mm allen wrench (**B**).

**NOTE:** Retaining spacers (**CC**) go between the projector and adapter plate (**AA**).

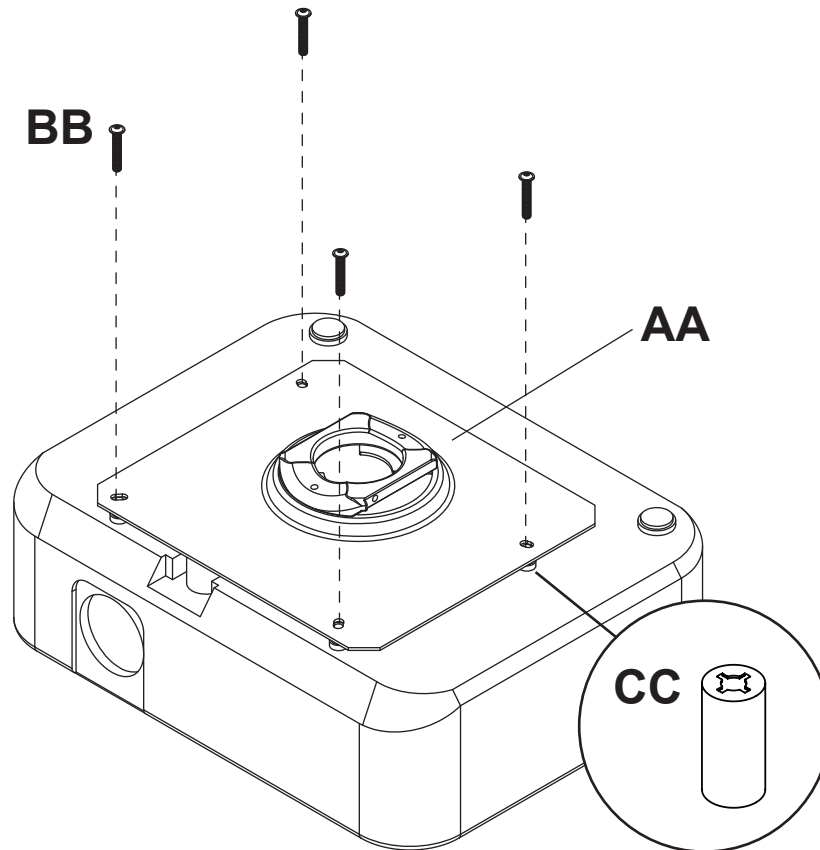

## Attaching Adapter Plate to Projector Mount

### ⚠ WARNING

- Do not lift more weight than you can handle. Use additional man power or mechanical lifting equipment to safely handle placement of the screen.

- 6** Slide connection block (EE) with projector into projector mount assembly (A) as shown. Tighten captive screw to secure projector to projector mount assembly (A).

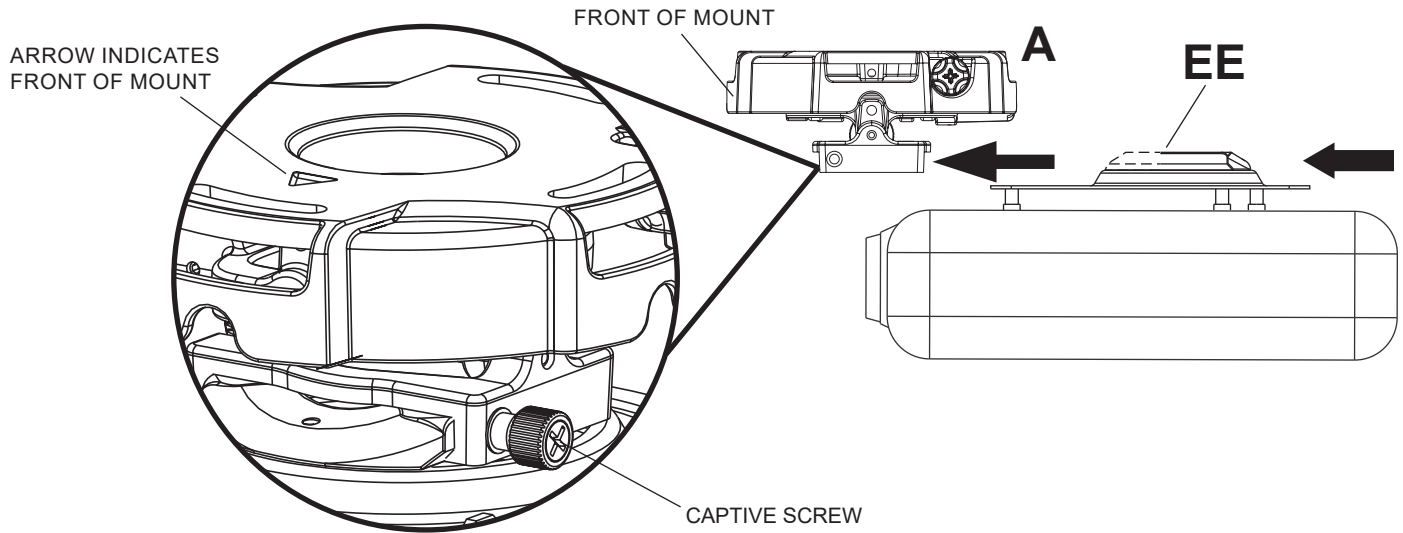

- 7** **IMPORTANT:** For security installations, insert one #10-32 x 1/4" socket pin screw (D) through projector mount assembly (A) and into connection block (EE) as shown in detail 1. Tighten screw using 4mm security allen wrench (B).

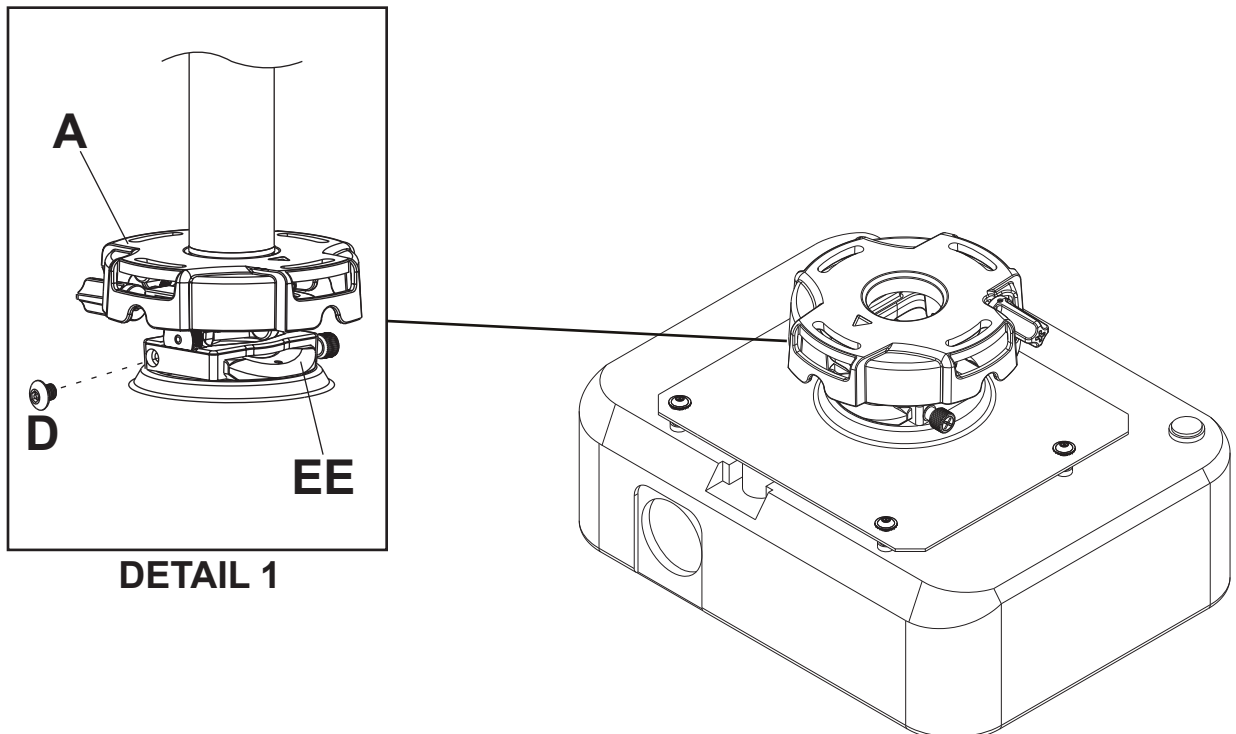



# Projector Alignment

**8** **To adjust yaw (swivel) for wood stud and concrete ceiling:** Loosen wood screws (F) if flush mounted to wood joists (page 5) or concrete ceilings (page 6), until projector mount can be rotated. Rotate mount to desired position and retighten screws.

**To adjust yaw (swivel) for extension column applications:** Loosen screw on projector mount assembly (A) indicated below until projector mount can be rotated. Rotate mount to desired position and retighten screw.

**To adjust pitch (forward and backward tilt):** Turn knob on back of mount as shown below. Pull knob out and turn by hand for easy adjustment or insert #2 phillips screwdriver in end of knob and turn.

**To adjust roll (side to side tilt):** Turn knob on side of mount as shown below. Pull knob out and turn by hand for easy adjustment or insert #2 phillips screwdriver in end of knob and turn.

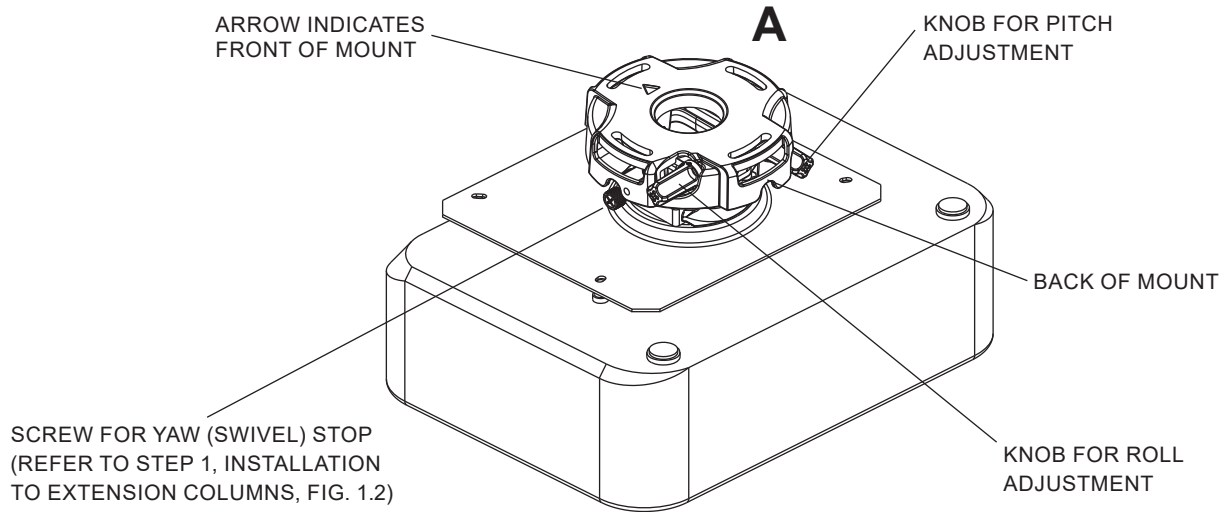

**8-1** **To prevent tampering with the pitch and roll adjustments:** Tighten the two tamper resistant security screws on the projector mount assembly using 4mm security allen wrench (B) to lock the pitch and roll adjustments as shown below. **Note:** Tighten screws firmly, but do not overtighten. Overtightening can damage the mount.

## CAUTION

- Do not adjust pitch or roll while tamper resistant security screws are fully engaged.
- Loosen the two tamper resistant security screws one complete turn before adjusting the projector mount assembly or damage may occur.

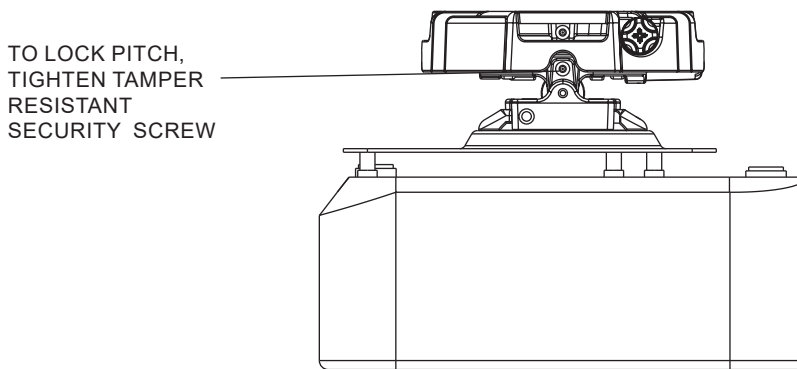

## SIDE VIEW