

# NEC MultiSync LCD8205

## LCD8205-FSK Floor Stand Kit

### User Instructions

---

-It is the responsibility of the installer to ensure this product is properly assembled.

-The Floor Stand Kit is designed to allow flexible placement of the LCD8205, in a variety of location.

#### Highlights

-Ultra-sturdy, all-steel construction.

-Black powdercoat finish.

-Includes leveling feet or castors.

-For use with the LCD8205 in landscape or portrait mode.

-Easily disassembles into three main pieces.

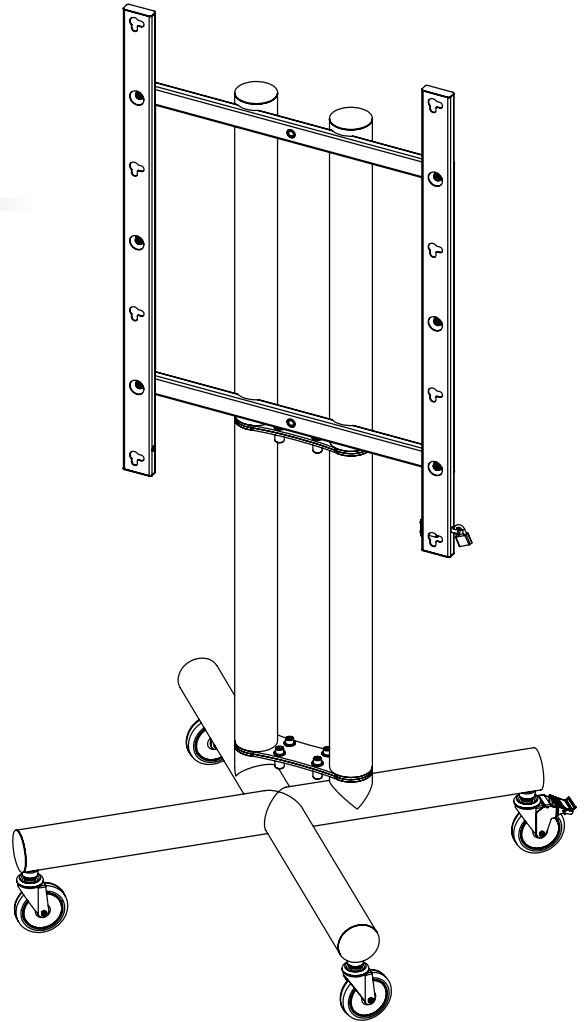

---

## Contents

Components .....	Page 2
Assembling the Floor Stand Kit .....	Pages 3-4
Installing the LCD8205 mount rails .....	Pages 5-6
Installing, and securing, the LCD8205.....	Pages 6-7

---

# Components

Includes all pieces shipped with Floor Stand Kit

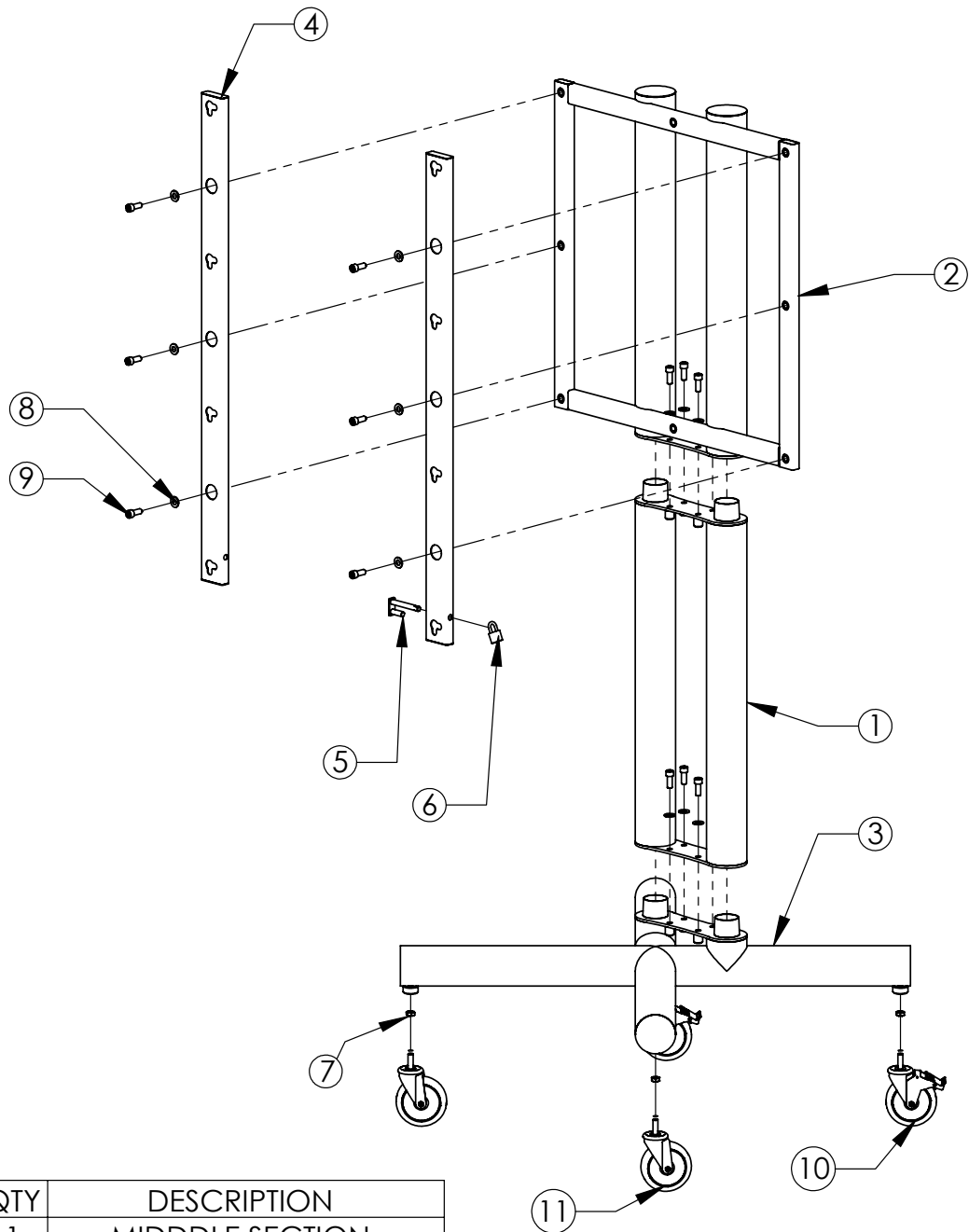

ITEM NO	QTY	DESCRIPTION
1	1	MIDDLE SECTION
2	1	TOP SECTION
3	1	BASE
4	2	KEYHOLE MOUNT TUBE
5	1	LOCK PIN
6	1	PADLOCK
7	4	1/2"-13 HEX NUT
8	14	1/2" FLAT WASHER
9	14	1/2"-13 x 1 1/4" BOLT
10	2	5" CASTOR w/BRAKE
11	2	5" CASTOR

# Assembling The Floor Stand Kit

Process begins with installation of castors or leveling feet.

## -Step One

Confirm that 1/2"-13 hex-nuts are threaded onto the stem of the castors. If not, be sure to do so. Once the hex-nuts are installed, the castors can be threaded into the base of the Floor Stand Kit. Reminder, installation of leveling feet is identical, except the feet need to be adjusted to ensure the stand will sit level.

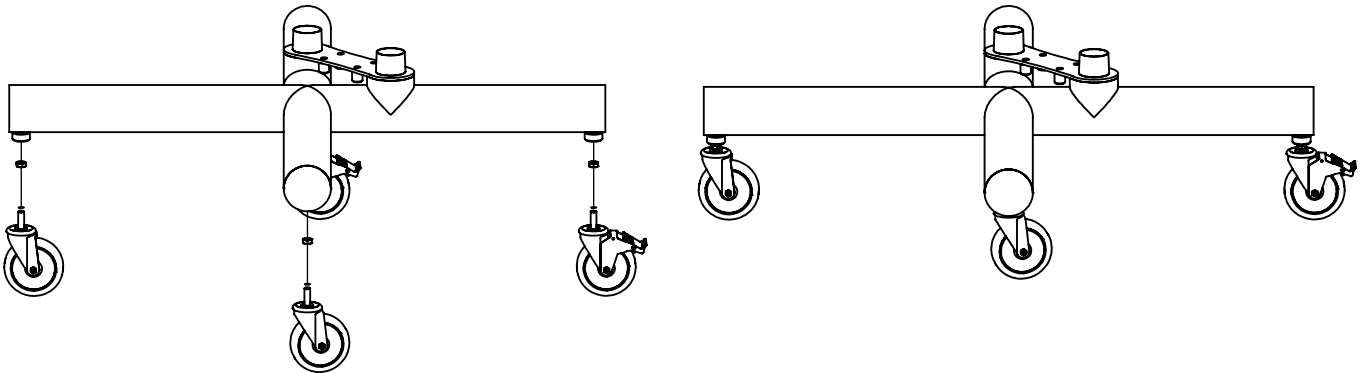

## -Step Two

Attach middle-section to the base. Slip the middle-section onto the positioning cylinders. Install the four 1/2"-13 Allen head bolts, and 1/2" flat washers.

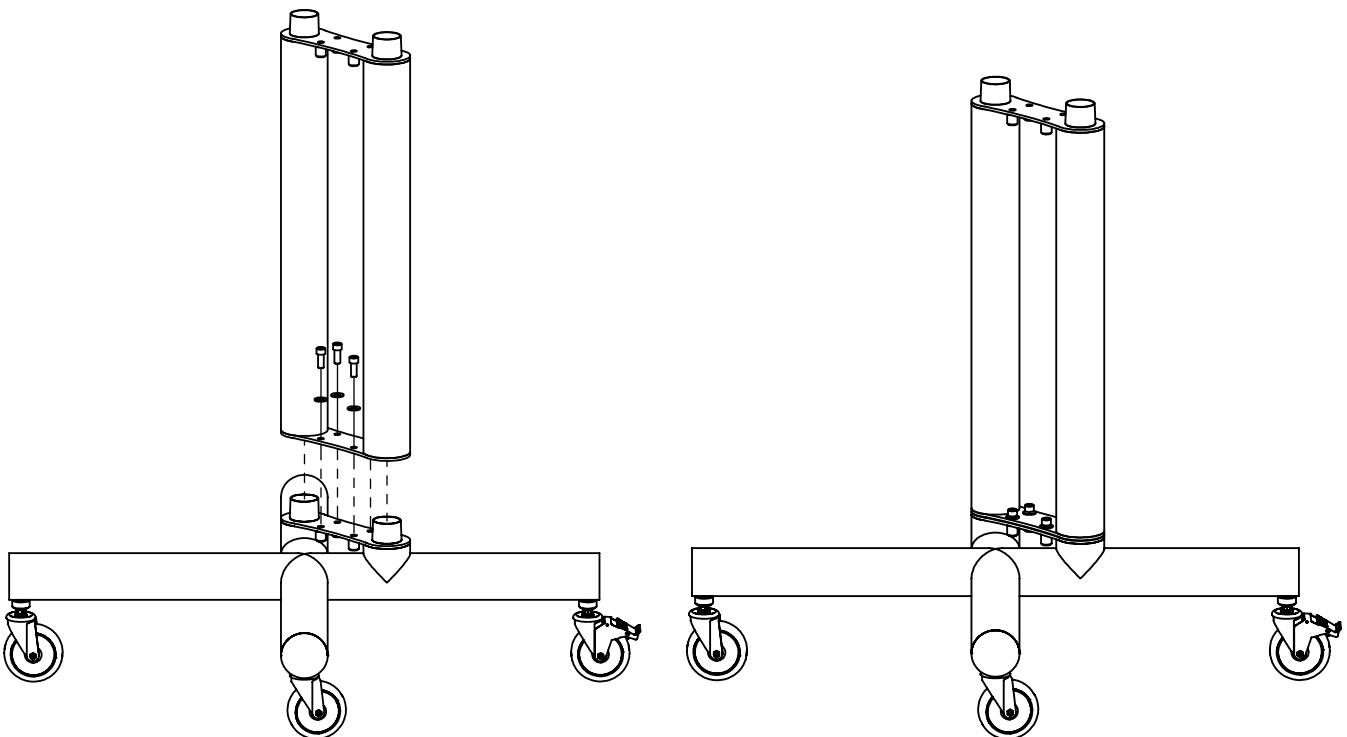

# Assembling The Floor Stand Kit

Continued from previous page.

## -Step Three

Attach top-section to the middle-section. Slip the top-section onto the positioning cylinders. Install the four 1/2"-13 Allen head bolts, and 1/2" flat washers.

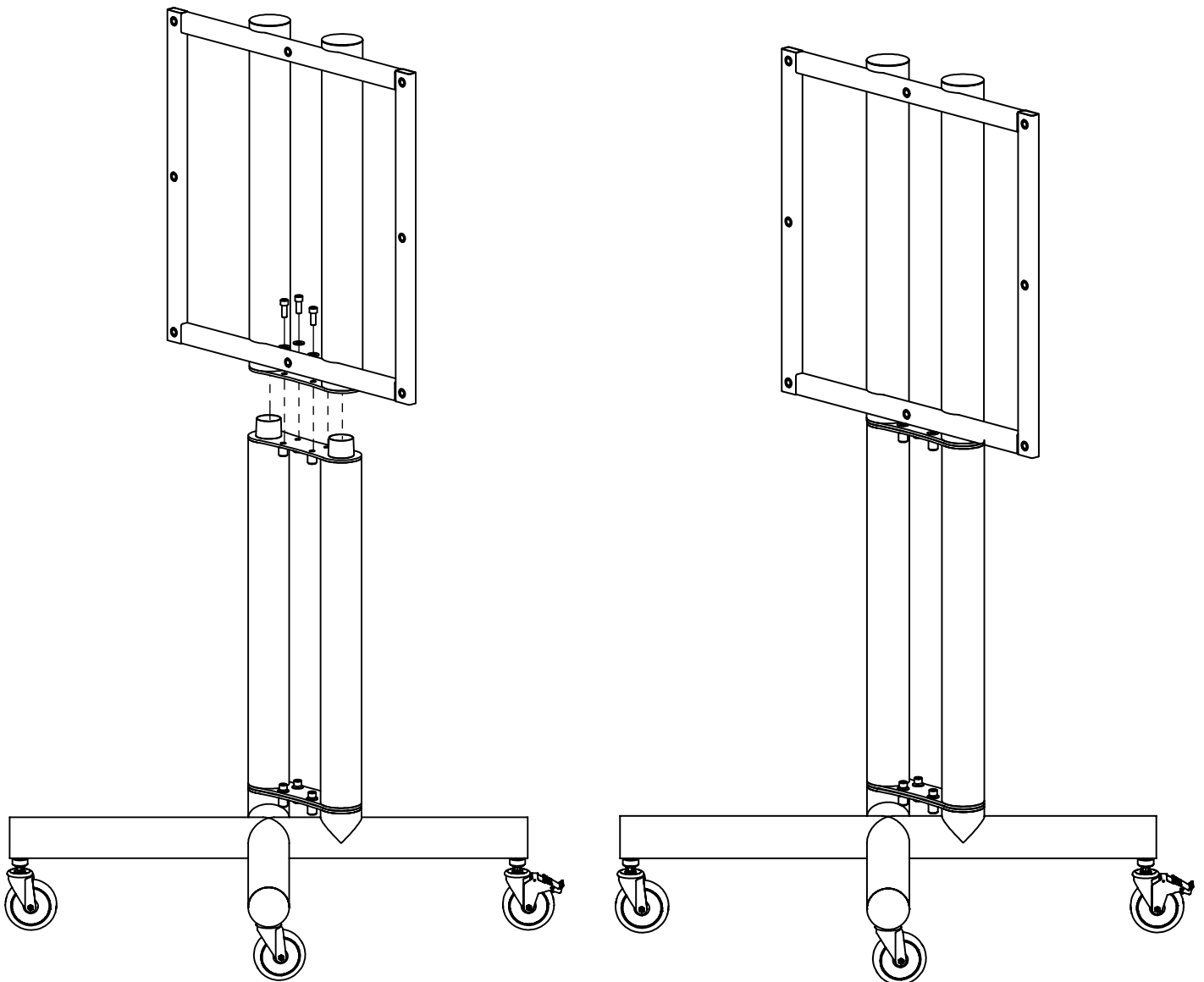

# Installing The LCD8205 Mount Rails

Continued from previous page.

## -Step Four

Before the display mounts can be installed, the orientation of the LCD8205 must be determined.

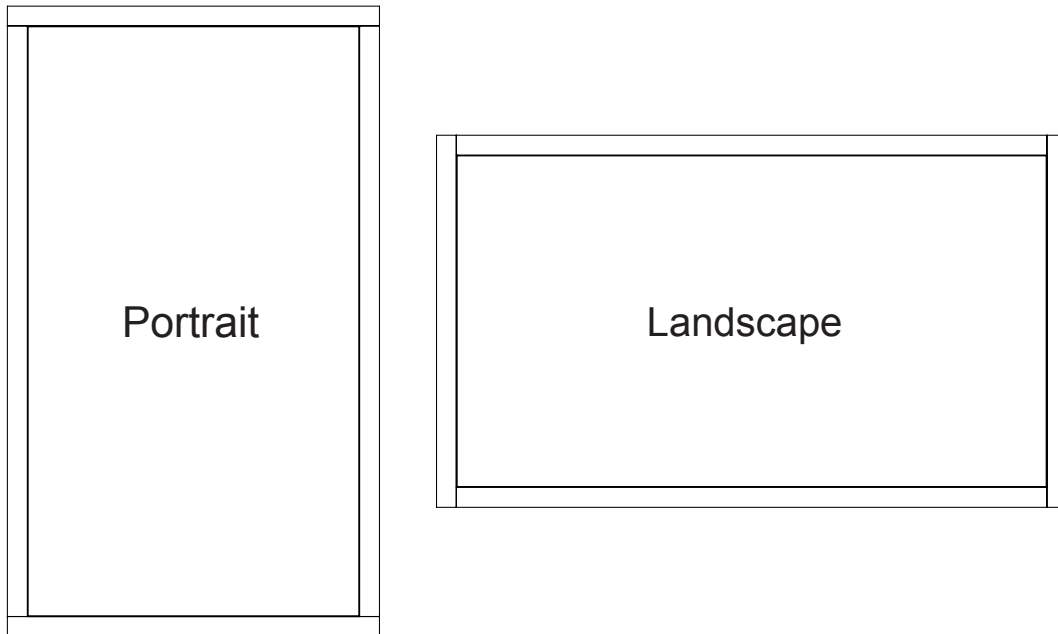

## -Step Five

Installing the display mounts in portrait orientation. Use six 1/2"-13 Allen head bolts and flat washers. Be sure that keyholes match the illustration.

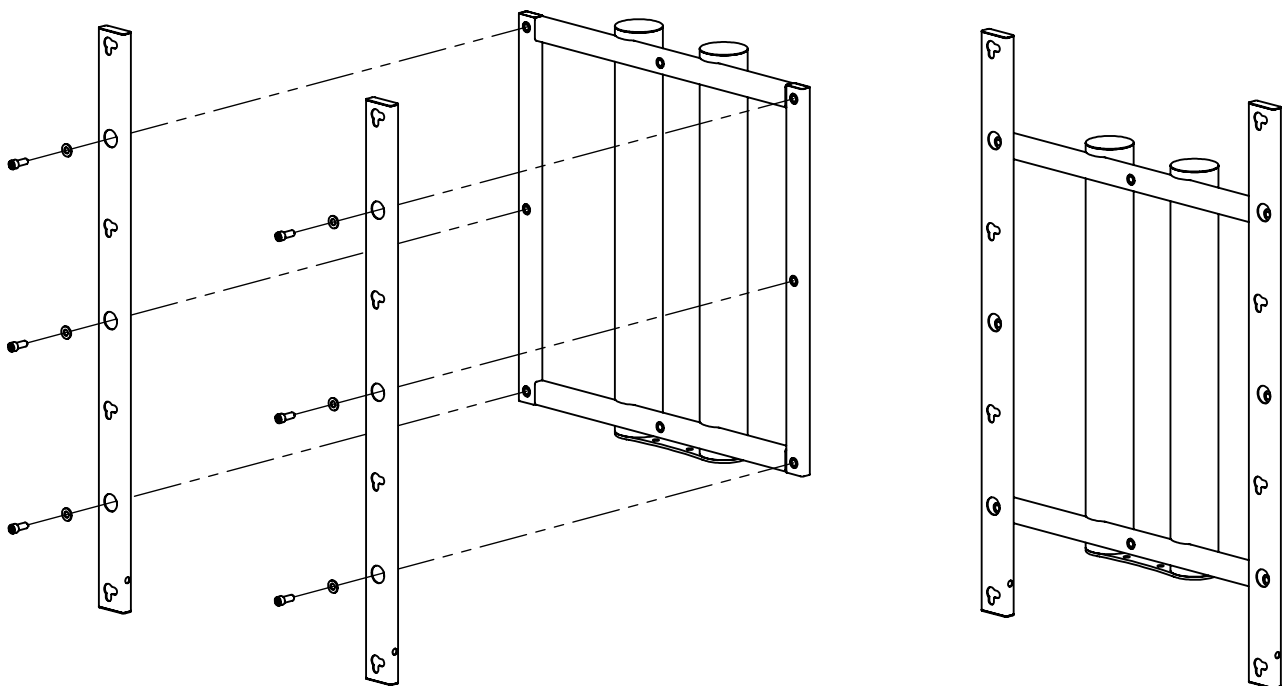

# Installing The LCD8205 Mount Rails

Continued from previous page.

## -Step Six

Installing the display mounts in landscape orientation. Use six 1/2"-13 Allen head bolts and flat washers. Be sure that keyholes match the illustration.

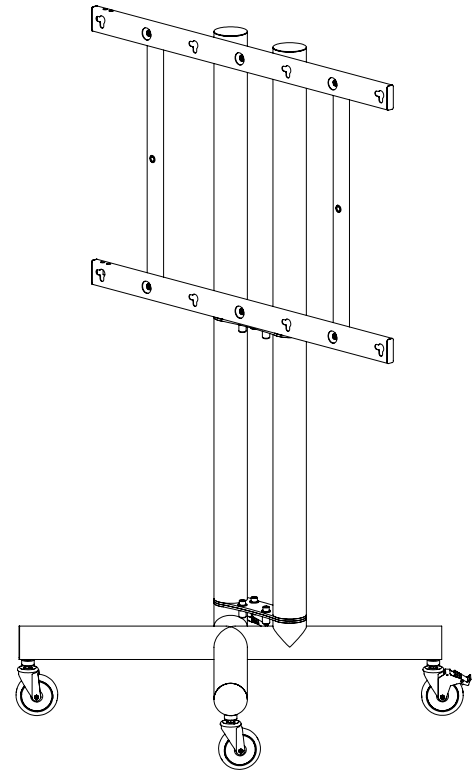
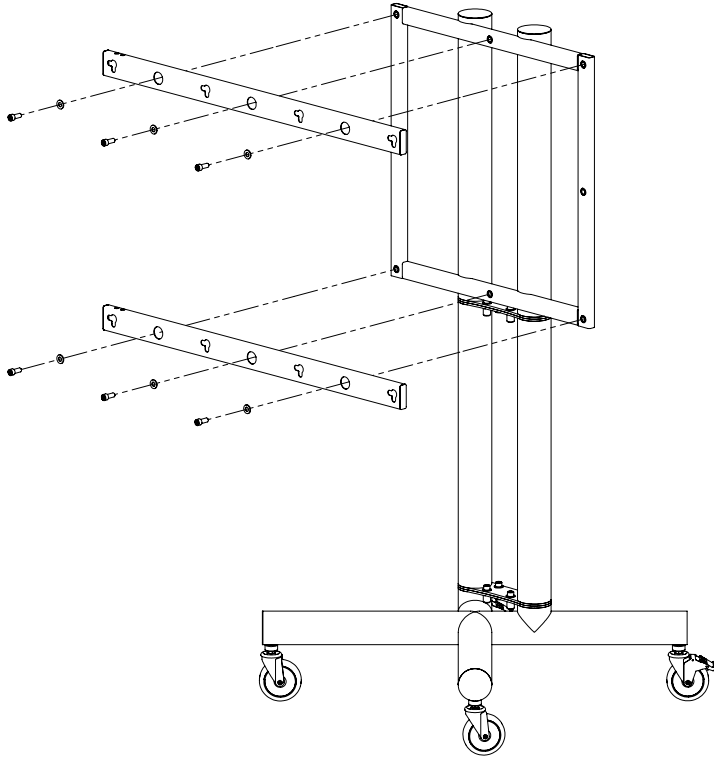

## -Step Seven

Install the display in the appropriate orientation.

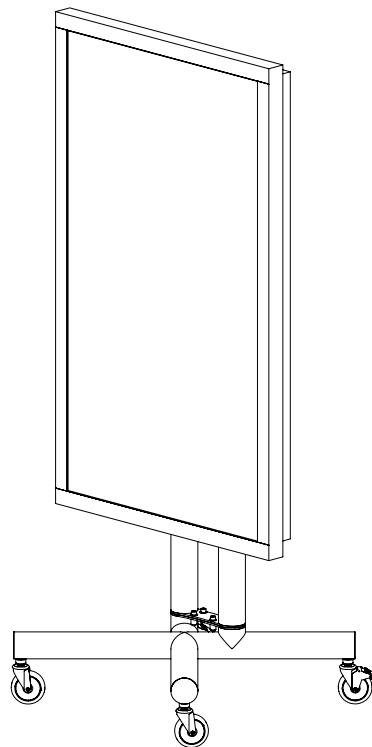
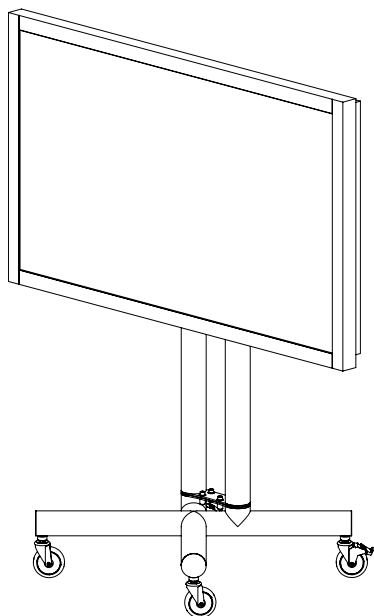

# Securing The LCD8205

Continued from previous page.

## -Step Eight(final step)

Install lock pin, and padlock. Shown without display mounted for ease of visualization.

